

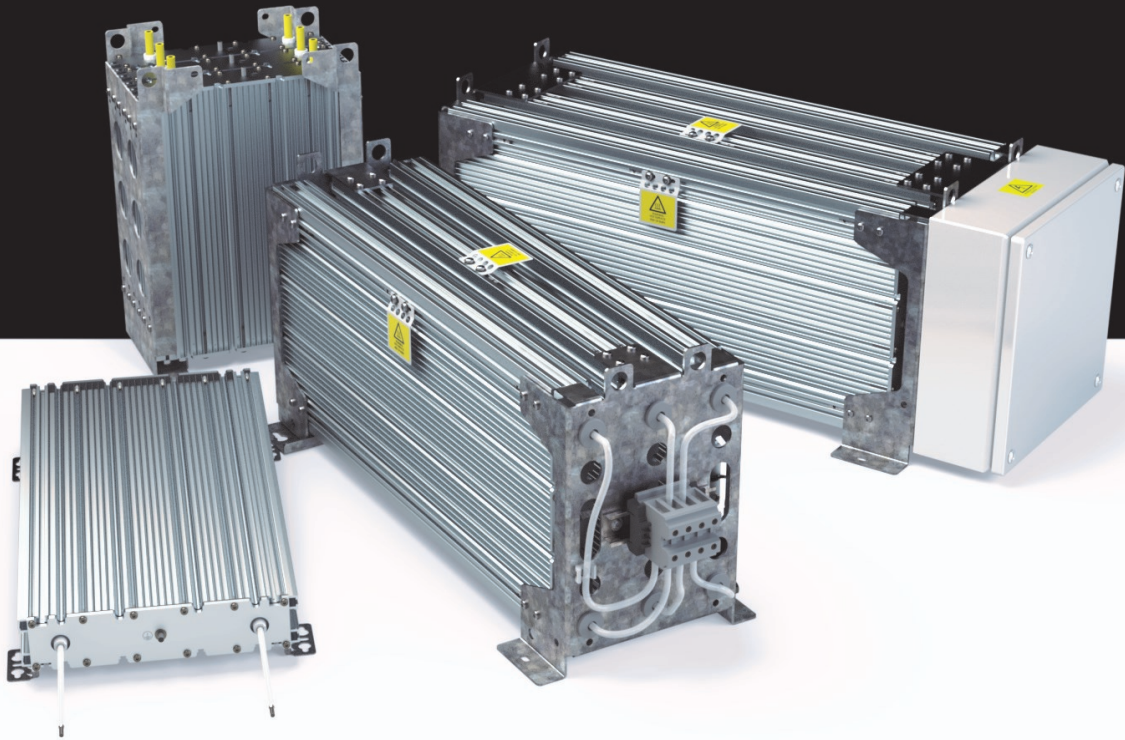

DANOTHERM™



CBS / CMQ / CVS (1000V)

HVBS (3000V)

- High Energy Dump resistors

- High pulse load applications
- Compact Construction; small dimensions
- Fully insulated; no external live parts
- High IP Classes
- Low thermal drift, 100ppm
- Low noise
- Thermal models for all types available on request
- Resistor components are UL approved / pending

General specifications

In this brochure the standard overview of four different aluminium case style resistors is given. Selecting the correct resistor type and options involves many considerations. Danotherm would very much like to support your choice. Together we can select the optimum resistor where all technical and commercial aspects are reviewed. Customer specific request for OEM solutions are very well possible, giving you an attractive solution.

Please, consult Danotherm. Our goal is to be a part of your success.

CBS / CMQ / CVS - 1000VAC/1400VDC

Nominal power [W] @ 40°C ambient / Ohm range min and max									
housing length	1 housing			1 housing			Ohm value		
	no Thermal switch			with Thermal switch			min -max Ω		
	CBS	CMQ	CVS	CBS	CMQ	CVS	CBS	CMQ	CVS
210	580	800	-	445	555	-	0.05-20	-	-
260	850	1100	-	685	855	-	0.07-35	-	-
330	1135	1500	-	870	1090	-	0.09-50	0.07-80	-
400	1375	1900	1995	1055	1320	1390	0.11-65	0.10-110	0.10-70
460	1585	2200	2310	1215	1520	1600	0.14-85	0.12-130	0.12-85
560	1925	2700	2830	1480	1850	1940	0.18-110	0.15-160	0.15-105
660	2270	3100	3250	1745	2180	2290	0.22-130	0.19-200	0.19-130
760	2770	3500	3670	2130	2660	2790	0.27-150	0.23-240	0.23-150
860	3190	3850	4040	2450	3060	3210	0.31-180	0.27-280	0.27-180
960	3565	4150	4350	2740	3420	3590	0.35-220	0.30-320	0.30-210

housing length	2 housings			3 housings			4 housings		
	no Thermal switch			no Thermal switch			no Thermal switch		
	CBS	CMQ	CVS	CBS	CMQ	CVS	CBS	CMQ	CVS
400	2340	2925	3070	3300	4350	4560	4400	5500	5830
460	2700	3375	3540	3800	5000	5250	5000	6500	6820
560	3270	4090	4290	4620	6050	6350	6100	8000	8400
660	3860	4825	5050	5500	7100	7450	7300	9100	9550
760	4700	5875	6160	6650	8500	8900	8800	11000	11500
860	5400	6750	7080	7660	10000	10500	10200	13000	13650
960	6060	7575	7950	8500	11200	11750	11300	14000	14700

HVBS - 3000VAC/4200VDC

HVBS-CH-XXX	Pn [W] @ 40°C According UL508	R [Ω] min - max $\pm 10\%$	double housings	triple housings	quadruple housings
HVBS 300	850	0.05 - 30	1500		
HVBS 370	1050	0.07 - 50	1800		
HVBS 440	1250	0.09 - 70	2100	2900	3500
HVBS 520	1365	0.10 - 90	2500	3700	5000
HVBS 620	1950	0.13 - 110	3200	4800	6400
HVBS 720	2500	0.15 - 140	3600	5400	7200
HVBS 820	2900	0.19 - 170	4800	7100	9600
HVBS 920	3200	0.22 - 200	5300	7900	10600
HVBS 1000	3500	0.25 - 220	6000	8800	12000

Temperature Coefficient:		100 ppm/K
Dielectric strength	HVBS	7000VAC @ 1 minute
	Other types	3500 VAC @ 1 minute
Insulation Resistance:		> 20M Ω / case housing
Overload:@ 1 sec pulse / hour		70 - 250 x (depending on resistor)
Overload:@ 5 sec pulse / hour		20 - 60 x (depending on resistor)
Environmental:		- 40 °C - 70 °C
De-rating cable version		Linear: 40°C = Pn to 70°C = 0.85 * Pn
De-rating TW 200°C version		Linear: 40°C = Pn to 70°C = 0.65 * Pn
De-rating vertical mounting		no de-rating
De-rating horizontal mounting		0.8 * Pn
De-rating at high altitudes	1000 m	no de-rating
	1500 m	0.94 * Pn
	3000 m	0.82 * Pn
Mounting instructions		It is recommended to keep a distance of 200mm to the nearest object to prevent heating of neighbouring components.
		If two or more brake resistors are mounted next to each other the distance between these should be 400mm. If this is less then the nominal power needs to be de-rated.
Cooling		The nominal power of the resistors refers to cooling conditions with Free Natural Air Cooling.
Vibration		Acc. To EN 60068-2-6 frequency range 1 - 100Hz Acceleration / Amplitude
	1 - 13 Hz	\pm 1mm
	13 - 100 Hz	@ \pm 0.7G
Corrosive resistance		Acc. IEC 60721-3-3/3K3 (C2 medium) 200 hours cyclic salt mist IEC 60068-2-52
Connection recommendations		To minimize EMC interference screened cables are recommended. in particular with PWM brake pattern.
Resistance tolerance		\pm 10% (optional 5%)
Working voltage CBS / CMQ / CVS	Cable version	UL: 1000VAC. IEC: 1000VAC / 1400VDC
	Conn. Box	UL: 600VAC. IEC: 690VAC / 1100VDC
Working voltage HVBS	Cable version	IEC: 3000VAC / 4200VDC
Time constant for heating up resistor		1000 - 3000s
Thermal switch *	Thermal switch	130 / 160 / 180 / 200 °C. 2.5A. 250 VAC NC
Minimum measuring voltage		2V
Minimum measuring current		10mA
Rated current / voltage		2.5A @ 250 VAC cos ϕ =1
Dielectric voltage		2000VAC (3500VAC between TS and R)
Temperature requirements on cables	IP 21	80°C
	IP 65	90°C

* optionally in CBS / CMQ / CVS

Construction and properties

- Compact dimensions
- Nominal power range from 455W–4070W
- Energy levels from 80kJ-2.5MJ per case housing (5s single pulse), depending on ohmic value
- Aluminium case housing for high IP rating
- IP50-IP65
- Internal ceramic supported wirewound spirals for lower ohmic values
- Nickel-Chrome 8020 alloy for low thermal drift
- Mica insulated for high dielectric strength
- Al_2O_3 or SiO_2 filled for high thermal capacity/high power overload capability
- Low surface temperature
- Low noise level
- High vibration withstand capability
- Thermal relief expansion mounting feet
- Optionally thermal switch or PT100 element for thermal protection guard.
- Cable (AWG 10–AWG4) or box connection up to 50mm²
- Multiple case housings (from 2-4 housings)
- Customized to your needs and application (OEM versions available)

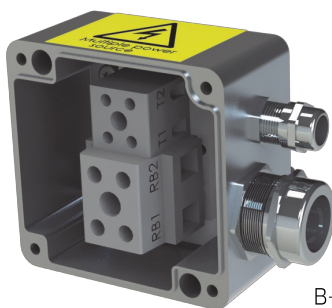

B-box
Single-body

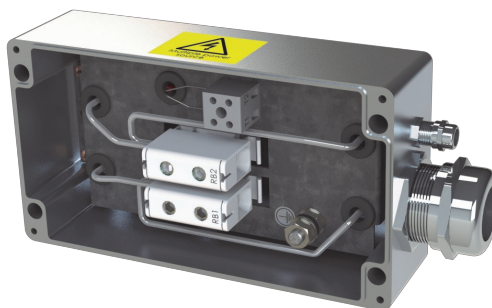

B-box
Multiple-housings

connection boxes	IP rating	cable gland	clamping range [mm]	braid diameter (min.) [mm]	elec. connection [mm ²]
B-box (single housing)	IP65	M25	9-16.6	7.5	0.75-10
D-box	IP21	M25	9-16.6	7.5	0.75-10
G-box	IP21	M40	19-28	15	2.5-50
B-box (multiple housings)	IP65	M32	11-21	9	2.5-50
B-box (multiple housings)	IP65	M40	19-28	15	2.5-50
thermal switch (optional)	-	M12	3-7	-	0.5-4

Mechanical drawings

Cable connection type IP50 CBS / CMQ / CVS -H ..C..

Length/type $L \pm 2$ mm	CBS		CMQ		CVS	
	5s load* kW	Weight kg	5s load* kW	Weight kg	5s load* kW	Weight kg
210 CH 001 22R	16	3.6	23	5.2	-	-
260 CH 001 18R	27	4.5	46	6.5	-	-
330 CH 001 13R	45	5.7	71	8.3	-	-
400 CH 001 10R	68	7.0	120	10.3	135	12.3
460 CH 001 6R5	92	8.2	150	12.0	190	14.5
560 CH 001 6R0	120	10.0	210	14.9	265	17.9
660 CH 001 4R5	160	12.0	260	17.7	340	21.4
760 CH 001 3R5	205	14.2	350	20.2	440	25.2
860 CH 001 2R5	185	16.3	350	23.0	500	28.7
960 CH 001 2R0	255	17.6	460	26.3	510	31.6
housing case dimensions						
Type	H	$W \pm 1$		$W1 \pm 1$		
CBS	47	218		230		
CMQ	50	290		304		
HVBS	50	290		304		
CVS	60	290		304		

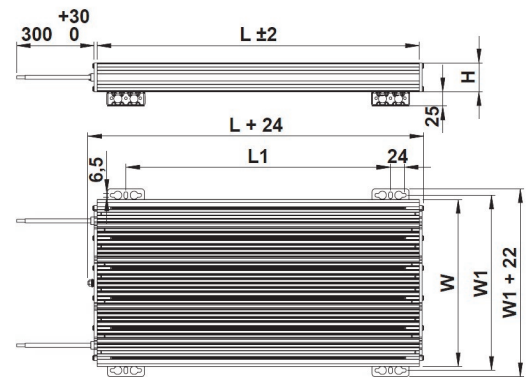

* Pulse rating depends on resistance value

Cable connection type IP50 HVBS -H ... CH... (3000VAC)

$L \pm 2$ mm	5s load* kW	Weight kg
HVBS 300 CH 001 15R	22.4	7.5
HVBS 370 CH 001 12R	41.3	9.3
HVBS 440 CH 001 10R	66	11.3
HVBS 520 CH 001 8R0	81	13.5
HVBS 620 CH 001 6R0	120	16.5
HVBS 720 CH 001 5R0	155	19.3
HVBS 820 CH 001 4R0	185	21.8
HVBS 920 CH 001 3R5	270	24.6
HVBS 1000 CH 001 3R0	300	27.4

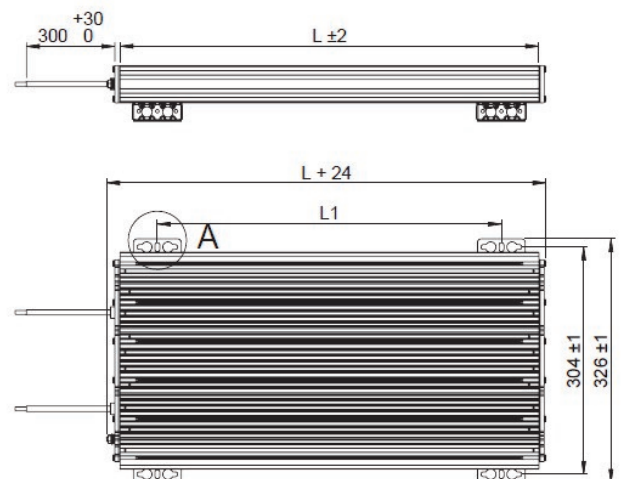

* Pulse rating depends on resistance value

HVBS High Voltage dump resistors are only offered with HV cable connection leads and no thermal switch

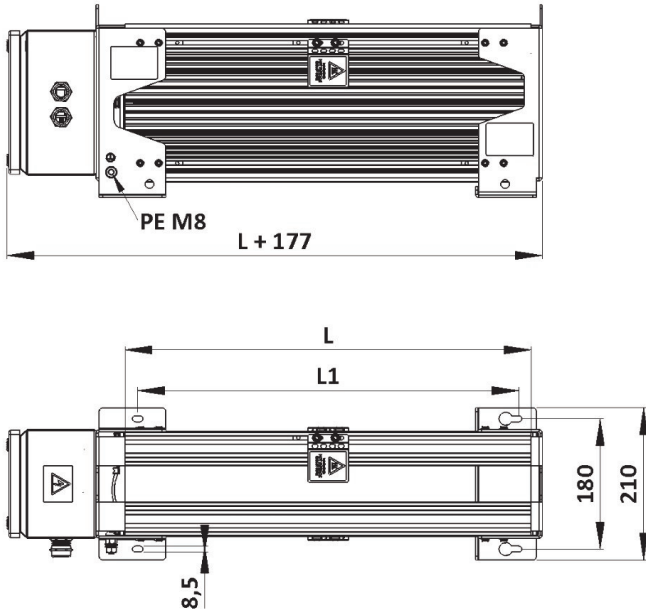

CBS Double housings, connection B-Box type,

$L \pm 2$ mm	5s load* kW	Weight kg
CBS 210 BGH 202 11R	32	9.2
CBS 260 BGH 202 9R0	54	11.0
CBS 330 BGH 202 6R5	90	13.4
CBS 400 BGH 202 5R0	136	16.0
CBS 460 BGH 202 3R3	184	18.4
CBS 560 BGH 202 3R0	240	22.0
CBS 660 BGH 202 2R3	320	26.0
CBS 760 BGH 202 1R8	410	30.4
CBS 860 BGH 202 1R3	510	34.6
CBS 960 BGH 202 1R0	510	37.2

CMQ Double housings, connection B-Box type, IP54–IP65

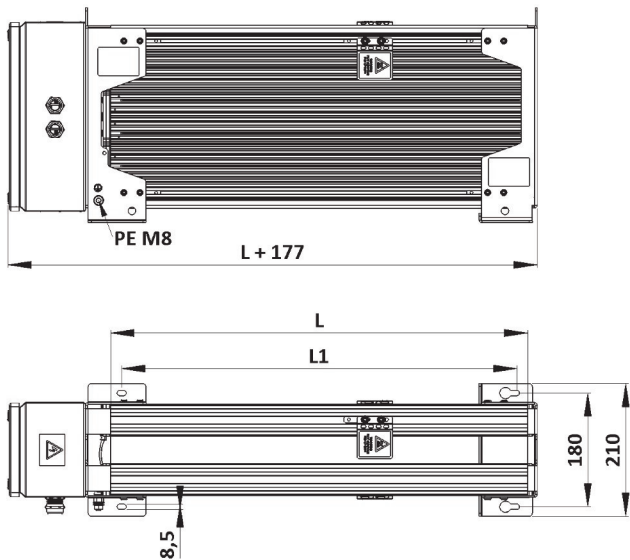

$L \pm 2$ mm	5s load* kW	Weight kg
CMQ 210 BHT 2x2 11R	46	12.4
CMQ 260 BHT 2x2 9R0	92	15.0
CMQ 330 BHT 2x2 6R5	142	18.6
CMQ 400 BHT 2x2 5R0	240	22.6
CMQ 460 BHT 2x2 3R3	300	26.0
CMQ 560 BHT 2x2 3R0	420	31.8
CMQ 660 BHT 2x2 2R3	520	37.4
CMQ 760 BHT 2x2 1R8	700	42.4
CMQ 860 BHT 2x2 1R3	700	48.0
CMQ 960 BHT 2x2 1R0	920	55

CBS Triple housings, cable type, IP50

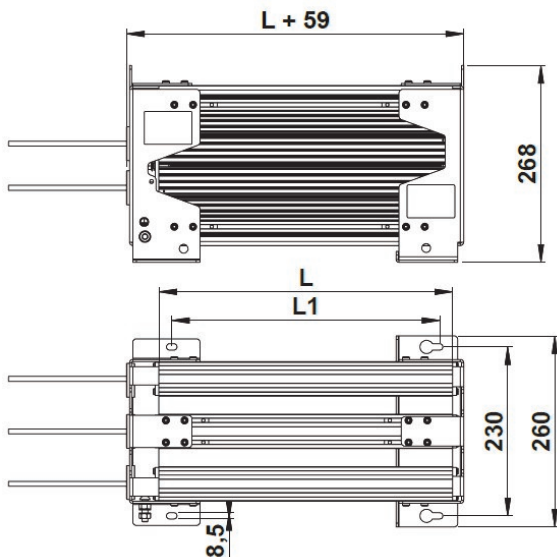

$L \pm 2$ mm	5s load* kW	Weight kg
CBS 210 CH 003 7R3	48	11.8
CBS 260 CH 003 6R0	81	14.5
CBS 330 CH 003 4R3	135	18.1
CBS 400 CH 003 3R3	204	22.0
CBS 460 CH 003 2R2	276	25.6
CBS 560 CH 003 3R0	360	31.0
CBS 660 CH 003 1R5	480	37.0
CBS 760 CH 003 1R2	615	43.6
CBS 860 CH 003 0R8	555	50
CBS 960 CH 003 0R7	765	54

CMQ Triple housings, DIN rail terminals K-type, IP00

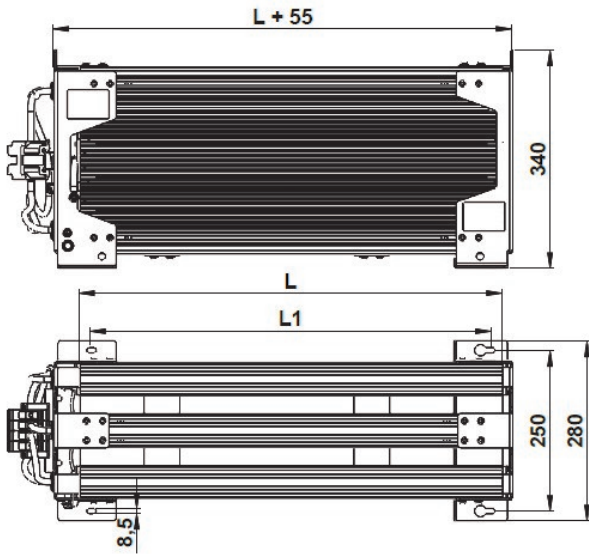

$L \pm 2$ mm	5s load* kW	Weight kg
CMQ 210 KH 203 7R3	69	11.8
CMQ 260 KH 203 6R0	138	14.5
CMQ 330 KH 203 4R3	213	18.1
CMQ 400 KH 203 3R3	360	22.0
CMQ 460 KH 203 2R2	450	25.6
CMQ 560 KH 203 3R0	630	31.0
CMQ 660 KH 203 1R5	780	37.0
CMQ 760 KH 203 1R2	1000	43.6
CMQ 860 KH 203 0R8	1000	49.9
CMQ 960 KH 203 0R7	1380	53.8

CMQ Quadruple housings, connection B-Box type, IP54

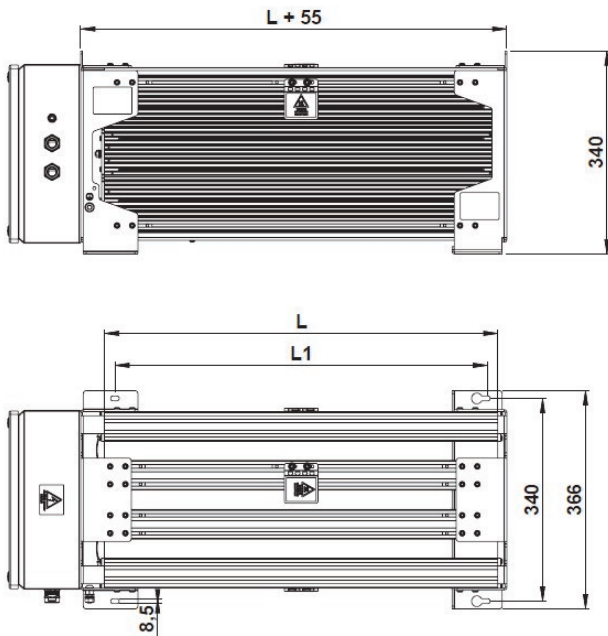

$L \pm 2$ mm	5s load* kW	Weight kg
CMQ 210 BHT 2x4 7R3	92	17.4
CMQ 260 BHT 2x4 6R0	180	21.0
CMQ 330 BHT 2x4 4R3	284	25.8
CMQ 400 BHT 2x4 3R3	480	31.0
CMQ 460 BHT 2x4 2R2	600	35.8
CMQ 560 BHT 2x4 3R0	840	43.0
CMQ 660 BHT 2x4 1R5	1000	51
CMQ 760 BHT 2x4 1R2	1400	60
CMQ 860 BHT 2x4 0R8	1400	68.
CMQ 960 BHT 2x4 0R7	1800	73

CBS Single to Quadruple housings 420/520mm, DIN rail terminals K-type, IP00

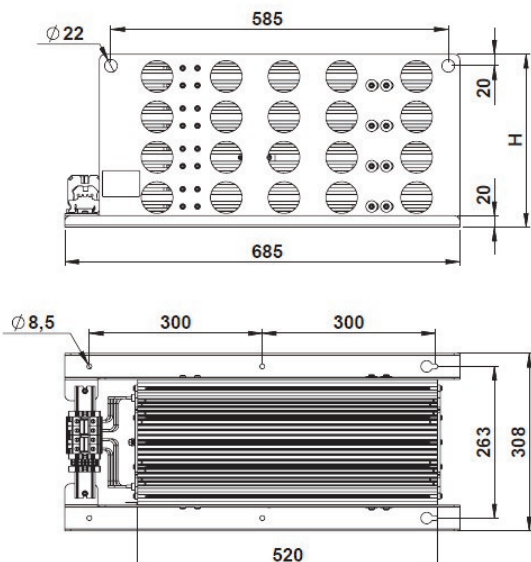

$L \pm 2$ mm	No. cases	$L \pm 2$ mm	H mm	Weight kg
CBS-H 420 KH 201 xxR	1	420	160	13.0
CBS-H 520 KH 201 xxR	1	520	160	13.5
CBS-H 420 KH 202 xxR	2	420	160	20.5
CBS-H 520 KH 202 xxR	2	520	160	22.5
CBS-H 420 KH 203 xxR	3	420	300	32.5
CBS-H 520 KH 203 xxR	3	520	300	34.5
CBS-H 420 KH 204 xxR	4	420	300	40.5
CBS-H 520 KH 204 xxR	4	520	300	42.5

All above tables are showing standard lengths.
Customer specified lengths are available.



CMQ / HVBS type with cable leads, IP50

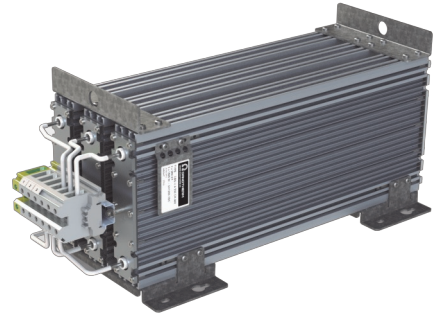

Quadruple CMQ type with DIN rail terminals, IP00



CMQ type with long connection box, IP54



Double CMQ type with connection box, IP54



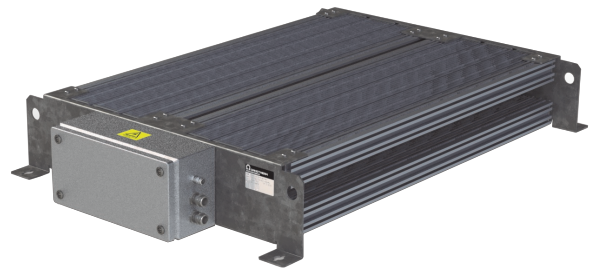

Double CMQ type with DIN rail terminals, IP00



Quadruple CMQ type with connection box, IP54

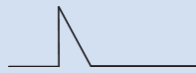

CMQ types with B-box IP54, quadruple, triple and double housings
2 cable glands M25 for resistor connection, 1 cable gland M12 for thermal switch



CBS	One single square pulse each 1800 seconds							
	Duty 5s [kW]	Max surface temp.	Duty 10s [kW]	Max surface temp.	Duty 20s [kW]	Max surface temp.	Duty 40s [kW]	Max surface temp.
CBS 210 22R	16	45	11	70	7.6	85	5.5	100
CBS 260 18R	27	65	19	75	13.1	90	9.5	120
CBS 330 13R	45	60	31	85	21.3	100	15.5	130
CBS 400 10R	68	70	44	90	31	110	21.6	140
CBS 460 6R5	92	85	59	100	40	120	28	150
CBS 560 6R0	120	85	77	100	52	120	36	150
CBS 660 4R5	160	70	100	110	66	130	46	160
CBS 760 3R5	205	95	125	110	83	130	56	170
CBS 860 2R5	255	85	155	120	100	140	67	170
CBS 960 2R0	250	95	160	110	105	140	73	170
	One single triangle pulse each 1800 seconds							
	Duty 5s [kW]	Max surface temp.	Duty 10s [kW]	Max surface temp.	Duty 20s [kW]	Max surface temp.	Duty 40s [kW]	Max surface temp.
CBS 210 22R	34	65	23	75	16	85	11.4	110
CBS 260 18R	57	70	40	80	27	95	20	120
CBS 330 13R	96	75	64	85	44	100	32	130
CBS 400 10R	145	80	95	95	64	110	45	140
CBS 460 6R5	195	90	125	100	83	120	57	150
CBS 560 6R0	255	90	160	100	110	120	75	160
CBS 660 4R5	340	95	215	110	140	130	95	170
CBS 760 3R5	440	100	270	120	175	140	120	170
CBS 860 2R5	540	110	330	120	210	140	140	180
CBS 960 2R0	540	100	340	120	225	140	150	180
	One single exponential pulse each 1800 seconds (e-curve)							
	$\tau = 5s$ [kW]	Max surface temp.	$\tau = 10s$ [kW]	Max surface temp.	$\tau = 20s$ [kW]	Max surface temp.	$\tau = 40s$ [kW]	Max surface temp.
CBS 210 22R	42	70	29	80	20	95	14	120
CBS 260 18R	71	75	49	90	34	110	24	140
CBS 330 13R	120	85	80	95	55	120	39	150
CBS 400 10R	180	90	115	110	79	130	55	170
CBS 460 6R5	245	100	155	120	100	140	70	180
CBS 560 6R0	310	100	200	120	135	140	92	180
CBS 660 4R5	410	110	260	130	170	150	115	200
CBS 760 3R5	530	110	330	130	215	160	145	200
CBS 860 2R5	650	120	400	140	260	170	175	210
CBS 960 2R0	670	110	420	130	275	160	190	210

The table above shows pulse power ratings for typical resistor sizes/lengths and typical ohmic values.

Formulas for e-curve :
$$p(t) = P_{max} \cdot e^{-2t/\tau} \quad E = \frac{\tau}{2} \cdot P_{max} \quad \tau = R \cdot C$$

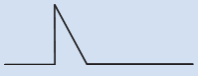
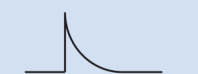

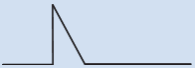
Pulse load table

CMQ	One single square pulse each 1800 seconds							
	Duty 5s [kW]	Max surface temp.	Duty 10s [kW]	Max surface temp.	Duty 20s [kW]	Max sur- face temp.	Duty 40s [kW]	Max surface temp.
CMQ 210 22R	23	65	16	70	11	85	8	110
CMQ 260 18R	46	75	31	85	21	100	15	130
CMQ 330 13R	71	75	47	90	32	110	23	140
CMQ 400 10R	120	85	75	100	49	120	34	150
CMQ 460 6R5	150	90	93	100	61	120	42	160
CMQ 560 6R0	210	100	130	110	83	130	57	160
CMQ 660 4R5	260	100	160	120	100	140	69	170
CMQ 760 3R5	350	110	210	120	130	150	88	180
CMQ 860 2R5	350	100	215	120	140	140	95	180
CMQ 960 2R0	460	120	275	130	175	150	115	190
	One single triangle pulse each 1800 seconds							
	Duty 5s [kW]	Max surface temp.	Duty 10s [kW]	Max surface temp.	Duty 20s [kW]	Max sur- face temp.	Duty 40s [kW]	Max surface temp.
CMQ 210 22R	50	65	34	75	23	85	17	110
CMQ 260 18R	100	75	66	85	44	100	31	130
CMQ 330 13R	150	80	99	90	67	110	47	140
CMQ 400 10R	250	90	160	100	105	120	71	160
CMQ 460 6R5	320	95	200	110	130	130	87	160
CMQ 560 6R0	450	100	275	120	175	140	120	170
CMQ 660 4R5	560	100	340	120	215	140	145	180
CMQ 760 3R5	740	120	450	130	280	150	185	190
CMQ 860 2R5	750	110	460	120	295	150	200	180
CMQ 960 2R0	970	120	590	140	370	160	245	200
	One single exponential pulse each 1800 seconds (e-curve)							
	$\tau = 5S$ [kW]	Max surface temp.	$\tau = 10S$ [kW]	Max surface temp.	$\tau = 20S$ [kW]	Max sur- face temp.	$\tau = 40S$ [kW]	Max surface temp.
CMQ 210 22R	62	70	42	80	29	100	21	120
CMQ 260 18R	125	85	81	100	55	120	38	150
CMQ 330 13R	185	90	125	100	83	130	58	160
CMQ 400 10R	310	100	195	120	130	140	87	180
CMQ 460 6R5	390	110	245	120	160	150	110	190
CMQ 560 6R0	540	120	340	130	220	160	145	200
CMQ 660 4R5	680	120	420	140	265	170	180	210
CMQ 760 3R5	900	130	550	150	350	180	225	220
CMQ 860 2R5	910	120	560	140	370	170	245	220
CMQ 960 2R0	1200	140	720	160	450	190	300	240

HVBS		One single square pulse each 1800 seconds							
		Duty 5s [kW]	Max surface temp.	Duty 10s [kW]	Max surface temp.	Duty 20s [kW]	Max surface temp.	Duty 40s [kW]	Max surface temp.
HVBS 300 15R		22.4	60	15.4	65	11	75	8	90
HVBS 370 12R		41.3	65	27.8	75	19.3	85	13.9	110
HVBS 440 10R		66	70	43.6	80	29.3	95	20.6	120
HVBS 520 8R0		81	75	54	85	37.1	100	26.6	130
HVBS 620 6R0		120	80	77	90	51	110	35.8	130
HVBS 720 5R0		155	80	98	90	65	110	45.1	140
HVBS 820 4R0		185	85	115	95	77	110	53	140
HVBS 920 3R5		270	95	165	110	105	120	69	150
HVBS 1000 3R0		300	95	180	110	115	130	77	150
		One single triangle pulse each 1800 seconds							
		Duty 5s [kW]	Max surface temp.	Duty 10s [kW]	Max surface temp.	Duty 20s [kW]	Max surface temp.	Duty 40s [kW]	Max surface temp.
HVBS 300 15R		48	60	33	65	23	75	16	95
HVBS 370 12R		88	65	59	75	41	90	29	110
HVBS 440 10R		145	75	93	85	62	100	43	120
HVBS 520 8R0		175	75	115	85	77	100	54	130
HVBS 620 6R0		255	80	165	90	110	110	74	140
HVBS 720 5R0		330	85	210	95	135	110	94	140
HVBS 820 4R0		400	85	250	95	160	120	110	140
HVBS 920 3R5		570	100	350	110	220	130	145	160
HVBS 1000 3R0		640	100	390	110	245	130	160	160
		One single exponential pulse each 1800 seconds (e-curve)							
		$\tau = 5s$ [kW]	Max surface temp.	$\tau = 10s$ [kW]	Max surface temp.	$\tau = 20s$ [kW]	Max surface temp.	$\tau = 40s$ [kW]	Max surface temp.
HVBS 300 15R		59	65	41	70	28	85	20	100
HVBS 370 12R		110	75	73	85	50	100	35	120
HVBS 440 10R		175	85	115	95	76	120	52	140
HVBS 520 8R0		215	85	140	100	95	120	67	150
HVBS 620 6R0		310	90	200	100	135	120	91	160
HVBS 720 5R0		400	95	255	110	170	130	115	160
HVBS 820 4R0		480	95	300	110	200	130	135	170
HVBS 920 3R5		690	110	420	120	270	150	180	180
HVBS 1000 3R0		770	110	470	130	300	150	200	190

The tables above show pulse power ratings for typical resistor sizes/lengths and typical ohmic values.

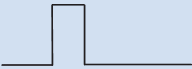
Pulse load table

CVS	One single square pulse each 1800 seconds							
	Duty 5s [kW]	Max surface temp.	Duty 10s [kW]	Max surface temp.	Duty 20s [kW]	Max surface temp.	Duty 40s [kW]	Max surface temp.
CVS 400 10R	135	80	83	90	52	100	35	120
CVS 460 6R5	190	90	115	95	71	110	46	130
CVS 560 6R0	265	95	155	100	97	120	63	140
CVS 660 4R5	340	100	200	110	120	120	79	150
CVS 760 3R5	440	100	255	120	155	130	99	160
CVS 860 2R5	500	110	290	120	175	130	115	160
CVS 960 2R0	510	100	300	110	180	130	120	160
	One single triangle pulse each 1800 seconds							
	Duty 5s [kW]	Max surface temp.	Duty 10s [kW]	Max surface temp.	Duty 20s [kW]	Max surface temp.	Duty 40s [kW]	Max surface temp.
CVS 400 10R	290	85	180	95	110	110	74	130
CVS 460 6R5	410	90	245	100	150	120	98	140
CVS 560 6R0	560	95	330	110	205	120	130	150
CVS 660 4R5	720	100	420	110	260	130	165	150
CVS 760 3R5	930	110	550	120	330	140	210	160
CVS 860 2R5	1050	110	620	120	370	140	235	160
CVS 960 2R0	1050	100	630	120	390	130	250	160
	One single exponential pulse each 1800 seconds (e-curve)							
	$\tau = 5s$ [kW]	Max surface temp.	$\tau = 10s$ [kW]	Max surface temp.	$\tau = 20s$ [kW]	Max surface temp.	$\tau = 40s$ [kW]	Max surface temp.
CVS 400 10R	350	95	220	100	140	120	92	150
CVS 460 6R5	490	100	295	120	185	130	120	160
CVS 560 6R0	670	110	410	120	250	140	160	170
CVS 660 4R5	860	110	510	130	320	150	205	180
CVS 760 3R5	1100	120	660	140	400	160	255	190
CVS 860 2R5	1250	120	740	140	460	160	295	200
CVS 960 2R0	1250	120	760	130	480	150	310	190

The table above shows pulse power ratings for typical resistor sizes/lengths and typical Ohm values.

Pulse load

The ability to withstand pulse-loads varies according to resistor size, length and diameter of the internal resistor wire. As such, it is impossible to create standard graphs that would apply to all customer applications. In some cases, the load-profile will be the combination of a square and a triangular pulse, such as is the case with Low Voltage Ride Through (LVRT) and Emergency Brake situations, as encountered in the Wind Power industry.

On request, Danotherm performs simulations based on the actual application and for guidance, has produced tables for various load-profiles for resistors with standard wire. The above table shown is based on a resistor with indicated ohmic value and standard wire thickness. Depending on the application, resistor construction can be adapted to optimally match the application. In the tables above, the peak powers of single rectangular, triangular and exponential pulses durations of 5 to 40 seconds.

Ingress Protection

The Ingress Protection rating (IP) value depends on the resistor and on the connection style. The basic IP rating for resistors is IP 50 but by the addition of gaskets, they can be increased to IP 54 or IP 65 which is also possible for resistors with flying leads. For resistors with connection box type B, the maximal IP value is 65. Resistors with connection boxes D and G have an IP 21 rating when mounted vertically and IP 20 when mounted horizontally.

IP values and their type-tests are well defined; for instance "IP 65" means dust cannot penetrate the box or if dust occurs internally, it will not influence the electrical properties. It should be able to withstand water jets from any direction with a certain pressure during 3 minutes; however, it does not mean that it can withstand continuous rain. If the resistor is used outdoors, then it should be protected against direct rain.

IP 65 rated resistors can be cleaned with a high pressure hose, but this can only be done when the resistor has cooled down to the ambient temperature, otherwise the water will cool the housing causing a partial vacuum inside, drawing in water.

Danotherm offers standard solutions for one to four cases combined into one compact configuration with pulse-withstand capability of 1MW (5MJ) and also OEM versions with a maximum of 20 resistors. Depending on the electrical connection, the IP class ranges from IP 00 to IP 65. Connections can be via a terminal box, DIN-rail terminals or cable lugs. These resistor types are also offered in high voltage versions and with higher ohmic values.

The salient features of Alpha resistors are that they have:

- Small dimensions
- Cool surfaces in operation
- High pulse-load capabilities
- High vibration capabilities
- No external electrically-live parts
- High IP classes
- Fail-safe capabilities (on request)
- low noise levels.

Ω NIBE

Danotherm Electric A/S
is a NIBE company

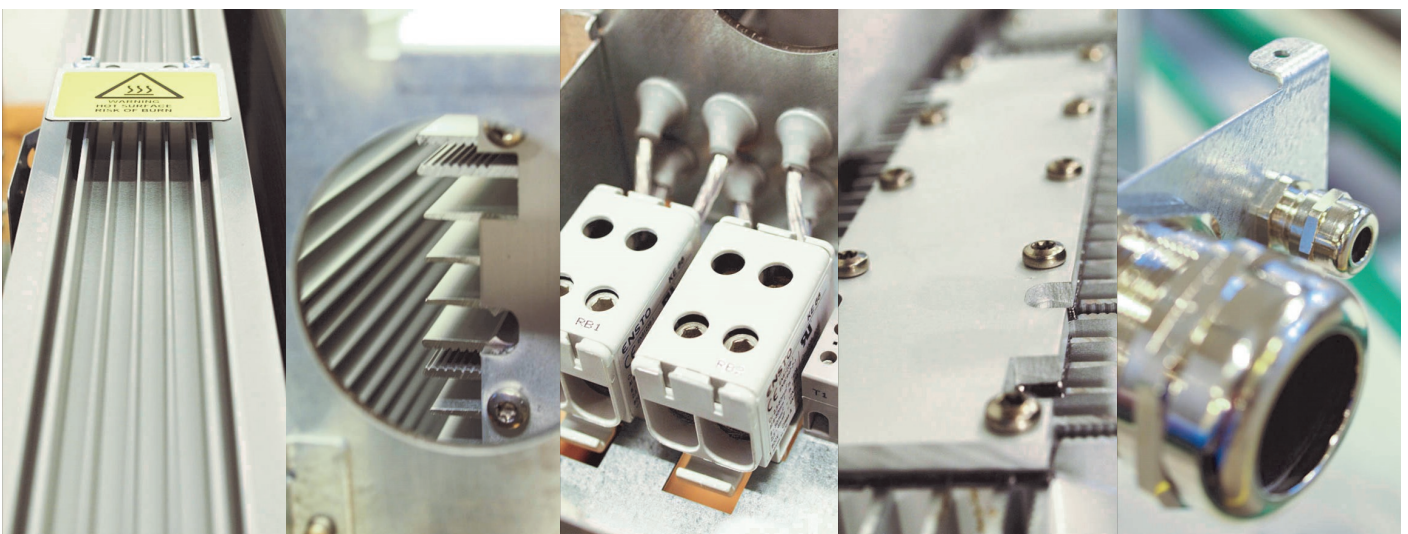

Danotherm has developed a thermal simulation method by which it is possible to optimize a resistor to a specified application. This gives following benefits:

- Short and fast engineering time, saving engineering costs
- Individual thermic model simulations can be done by Danotherm or handled by the customer. Individual thermic models are available on request.
- Simulation software for electrical circuits can be used for thermal simulations (P Spice, Matlab, Plecs or any other)
- For more complex loads a data file (like csv) can be used for input
- Optimizing the design, reducing overall size and costs
- Proof of capability is given without even building and testing samples

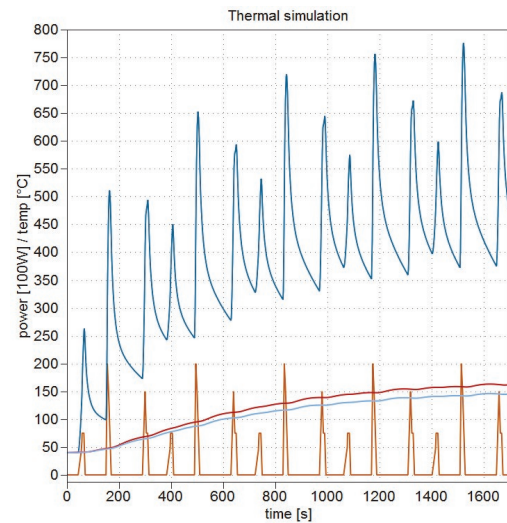
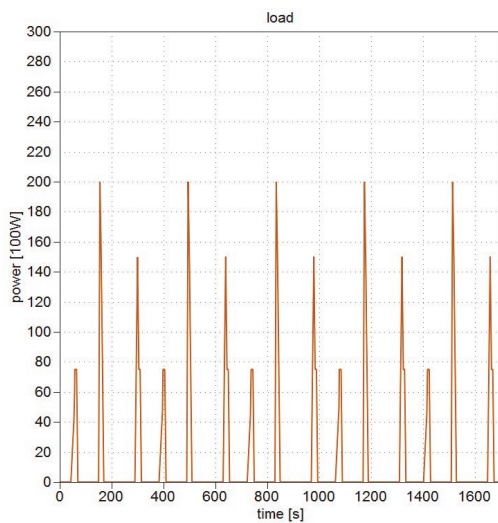
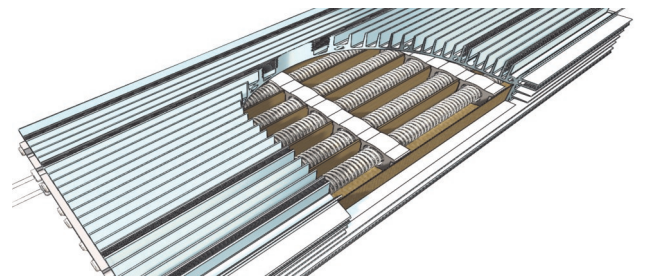
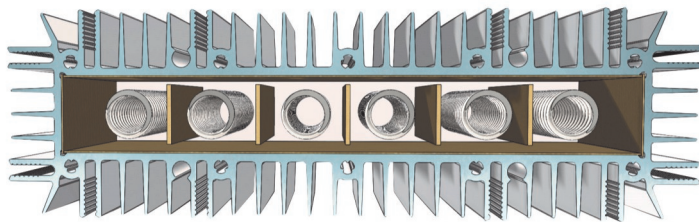

Measured on site: Brake Power saved in .cvs file.

Other possibilities could be a description of a typical or worst case brake pulse and a repeat cycle.

Simulation made by Danotherm

Results of temperature simulation of specified load in a suggested resistor type.

Thermal Model of ALPHA Resistor

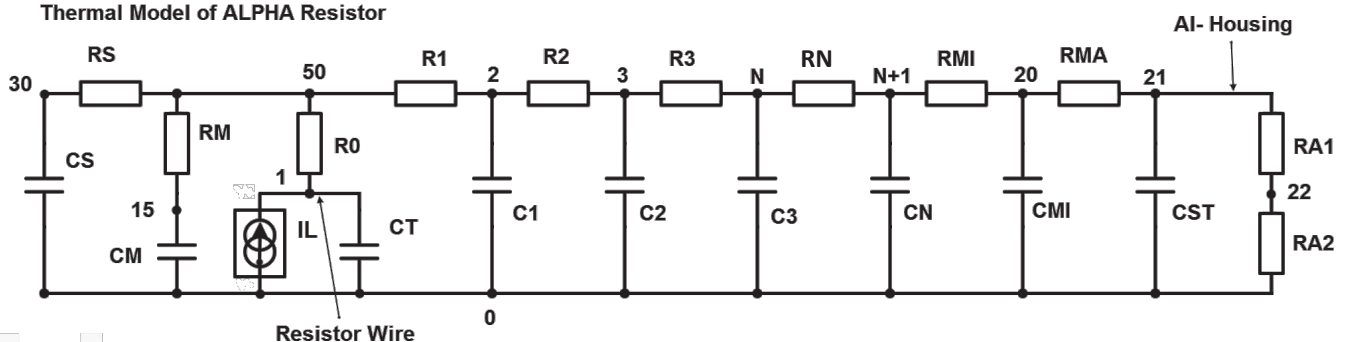

Danotherm resistors are used as:

- Pre-charge for DC-link (super) capacitors
- Pre-magnetization of power transformers
- Brake resistors for industrial drive systems
- Emergency stops in (gas) turbines

Danotherm resistors are used in:

- Elevators
- Escalators
- Cranes
- Vessels
- Wind turbines
- (Trolley)busses
- Trams / Metros / Trains (auxiliary circuits)
- Conveyer belts
- Transformers
- Turbines
- Excavation machines

Danotherm supports your request. The very start is your specification of the application, the load and environmental conditions. Ideally, a power-time graph is presented which forms the basis of the thermal simulation. If such graph is not available, the electrical circuit of the application is build in the simulation software. It is also possible to use a data file as input for the load. Such file can be build by measurements on the site or they come from another simulation software program.

The next step is to feed the generated power losses into the thermal model. Each resistor which its physical properties gets its own, unique, thermal model. With the simulation the temperatures inside the resistor and of the outside housing surface, are simulated. Here, the maximum temperature values are observed and at the same time care is taken not to over dimension the resistor.

When the type and internal construction of the resistor is defined, the resistor will be further tailored to the customers needs. Connection boxes, connection cable sizes, cable glands, IP ratings, mounting brackets, metal surface treatment, auxiliary circuits, such as Pt100 sensors and thermal switches, are all considered.

Finally, packing and shipping is an important topic. The resistors should be safely packed to prevent damage during transport and at the same time the costs for shipping and packing must be considered. Together with our customers the best option is chosen.



Overview of the ALPHA resistor family (IP00-IP65)

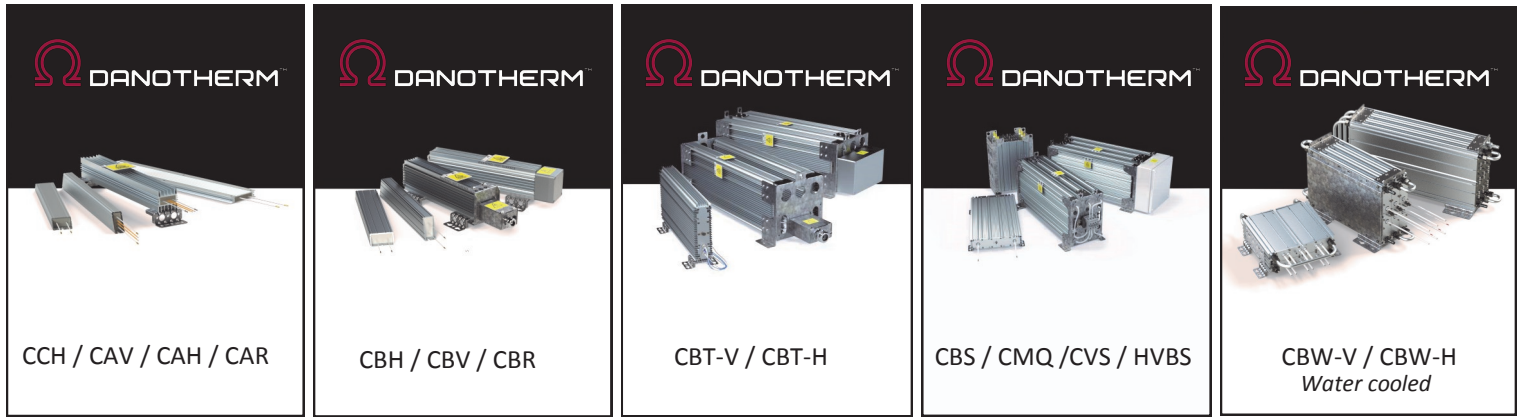

Power: 60-410W	Power: 85W-1.7kW	Power: 410W-12kW	Power: 445W-15kW	Power: 860W-25kW
	9-150kJ @5s	25-550kJ @5s	80kJ-2.5MJ @5s	6.4kJ-1.1MJ @5s
- Applications				
Charge / Discharge	High Pulse load	High Pulse load	High Pulse load	Short recovery time
Brake	Brake	Brake	Brake	Brake
Filter	Filter	Filter	Medium voltage	Filter
	Charge / Discharge	Charge / Discharge	Charge / Discharge	High Pulse load

Other resistor types from Danotherm (IP00-IP66)



Multi purpose	Outdoor & Marine	Filter	Medium & High voltage	Filter & load
Power: 100W-5kW	Power: 1-500kW	Power: 4-200kW	Power: 500W->	Power: 5kW-1MW
Ceramic wirewound	Steel tube	Wirewound	Steel grid	Steel tube

CMQ-H 400 CH(T) 281 22R KT

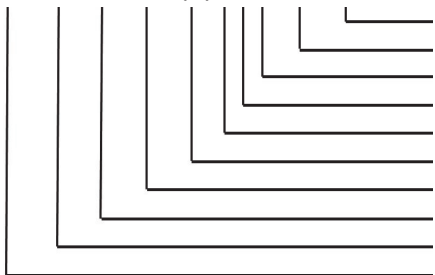

- Thermal drift; standard T=100ppm, Tolerance; standard K=± 10%
- Ohm value (Example 2R2=2.2Ω, / 22R = 22Ω)
- Number of case style housings (1, 2, 3 or 4)
- Thermal switch temp; 5=130°C / 6=160°C / 7=180°C / 8=200°C
- 0=cable connection, 2=connection box type
- T=Thermal switch, option, (normally closed)
- Connection style; C=cable / B=IP65 box / K=DIN rail IP00
- Length of resistor housing in mm
- H=horizontal mounting feet / V=vertical mounting feet
- Housing case style; CBS / CMQ / HVBS / CVS

Danotherm Electric A/S
 Naesbyvej 20
 DK-2610 Roedovre
 Denmark
 CVR 1012 6061

DAN EN 16.5043.R1
 22MAY2017