

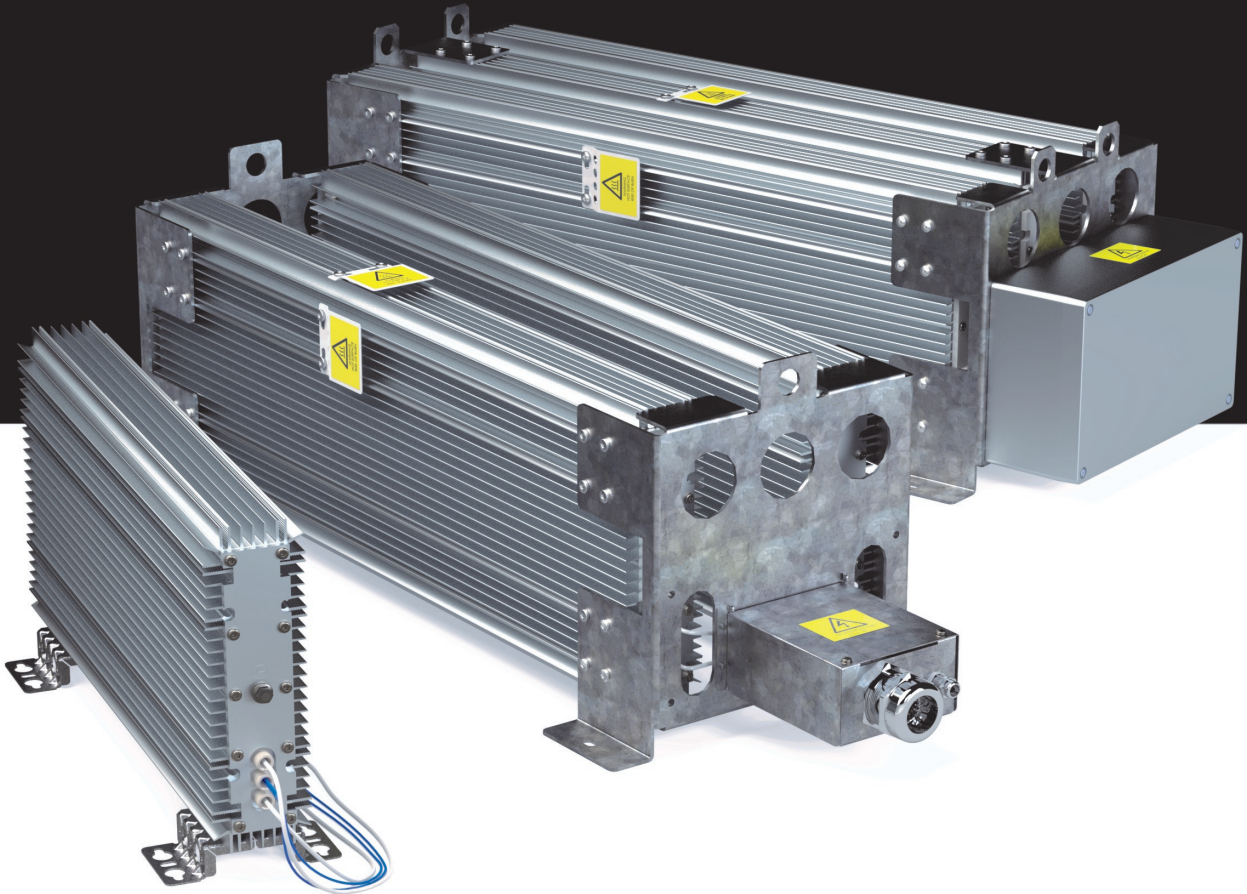

DANOTHERM™



CBT-H / CBT-V

- Brake resistors

- General-purpose applications; High pulse load and High average load
- Compact Construction; small dimensions
- Fully insulated; no external live parts
- High IP Classes
- Low thermal drift. 100ppm
- Fail Safe capabilities on request
- Low noise
- Thermal models for all types available on request
- Resistor components are UL approved

CBT 1 / 2 / 3 / and 4 housing cases

Pn [W] @ 40°C According UL508							
CBT-BH(T)-XXX	1 body	max case temp. [°C]	R [Ω] min - max ± 10%	Pn [W] @ 40°C			
	Pn [W] @ 40°C According UL508			1 case	2 cases	3 cases	4 cases
TS: Thermal switch	no TS			TS 200°C	no TS, max case temp. 250°C		
CBT 180	455	270	0.04 - 13	410			
CBT 210	585	270	0.05 - 2000	530			
CBT 260	830	280	0.07 - 2000	750			
CBT 330	1350	280	0.09 - 2000	1225			
CBT 400	1650	290	0.11 - 2000	1495	2200	3000	4000
CBT 460	1900	300	0.14 - 2000	1725	2800	4200	5600
CBT 560	2310	310	0.18 - 110	2095	3500	5200	6900
CBT 660	2720	320	0.22 - 130	2470	4200	6300	8400
CBT 760	3200	330	0.27 - 150	2905	5000	7200	9600
CBT 860	3640	340	0.31- 180	3305	5500	8000	10800
CBT 960	4070	350	0.35 - 220	3695	6900	9000	12000

Construction and properties

- Compact dimensions
- Nominal power range from 455W–4070W
- Energy levels from 25kJ-550kJ per case housing (5s duty,120s cycle), depending on ohmic value
- Aluminium case housing for high IP rating
- IP50-IP65
- Internal ceramic supported wirewound spirals for lower ohmic values
- Internal mica supported wirewound elements for higher ohmic values
- Nickel-Chrome 8020 alloy for low thermal drift
- Mica insulated for high dielectric strength
- Al₂O₃ or SiO₂ filled for high thermal capacity/ high power overload capability
- Low surface temperature
- Low noise level
- High vibration withstand capability
- Thermal relief expansion mounting feet
- Optional thermal switch or PT100 element for thermal protection
- Cable (AWG 14–AWG4) or box connection up to 50mm²
- Multiple case housings (from 2-4 housings)
- Customized to your needs and application (OEM versions available)
- For UL approval, consult Danotherm



Temperature Coefficient:		100 ppm/K
Dielectric strength		3500 VAC @ 1 minute
Isolation Resistance:		> 20M Ω / case housing
Overload:@ 1 sec pulse / hour		40 - 120 x (depending on resistor)
Overload:@ 5 sec pulse / hour		10 - 27 x (depending on resistor)
Environmental:		- 40 °C / +70 °C
De-rating cable version		Linear: 40°C = Pn to 70°C = 0.85 * Pn
De-rating TW 200°C version		Linear: 40°C = Pn to 70°C = 0.65 * Pn
De-rating vertical mounting		no de-rating
De-rating horizontal mounting		0.8 * Pn
De-rating at high altitudes	1000 m	no de-rating
	1500 m	0.94 * Pn
	3000 m	0.82 * Pn
Mounting instructions		It is recommended to keep a distance of 200mm to the nearest object to prevent heating of neighbouring component.
		If two or more brake resistors are mounted next to each other the distance between these should be 400mm. If this is less then the nominal power needs to be de-rated.
Cooling		The nominal power of the resistors refers to cooling conditions with Free Natural Air Cooling.
Vibration		Acc. To EN 60068-2-6 frequency range 1 - 100Hz Acceleration / Amplitude
	1 - 13 Hz	± 1mm
	13 - 100 Hz	@ ± 0.7G
Corrosive resistance		Acc. IEC 60721-3-3/3K3 (C2 medium) 200 hours cyclic salt mist IEC 60068-2-52
Connection recommendations		To minimize EMC interference screened cables are recommended. in particular with any PWM brake pattern.
Resistance tolerance		± 10% (optional 5%)
Working voltage	cable	UL: 1000VAC. IEC: 1000VAC / 1400VDC
	conn. Box	UL: 600VAC. IEC: 690VAC / 1100VDC
Time constant for heating up		1000 - 3000s
Thermal switch (optional)		130 / 160 / 180 / 200 °C. 2A. 250 VAC NC
Minimum voltage	Thermal switch	2V
Minimum current		10mA
Rated current / voltage		2.5A @ 250 VAC cos ϕ =1
Dielectric voltage		2000VAC (3500VAC between TS and R)
Temperature requirements on cables		IP 21
	IP 65	90°C

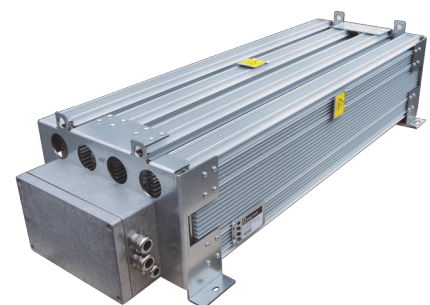
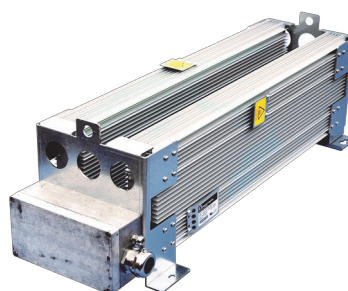
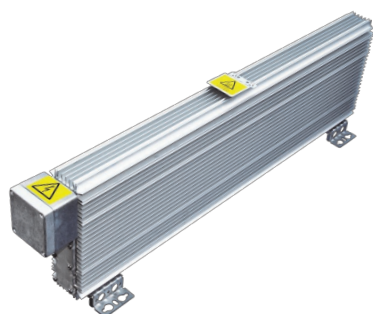

Mechanical drawings

Cable connection IP50 type CBT-H ..C..

P_n	Duty* 5/120	Horizontal type CBT -	$L \pm 2$	$L1 \pm 2$	Weight (SiO2)	Resistance Range
kW	kW	IP50	mm	mm	kg	Ω
0.45	6	-H 180 C(H)(T) 0X1	180	70	3.1	0.04 - 13
0.58	10.1	-H 210 C(H)(T) 0X1	210	110	3.6	0.05 - 2000
0.83	17.9	-H 260 C(H)(T) 0X1	260	160	4.5	0.07 - 2000
1.35	27.5	-H 330 C(H)(T) 0X1	330	230	5.9	0.09 - 2000
1.65	37	-H 400 C(H)(T) 0X1	400	300	7.3	0.11 - 2000
1.9	48	-H 460 C(H)(T) 0X1	460	360	8.5	0.14 - 2000
2.3	58	-H 560 C(H)(T) 0X1	560	460	10	0.18 - 110
2.7	69	-H 660 C(H)(T) 0X1	660	560	12	0.22 - 130
3.2	82	-H 760 C(H)(T) 0X1	760	660	13.8	0.27 - 150
3.6	95	-H 860 C(H)(T) 0X1	860	760	16	0.31 - 180
4.1	111	-H 960 C(H)(T) 0X1	960	860	17.8	0.35 - 220

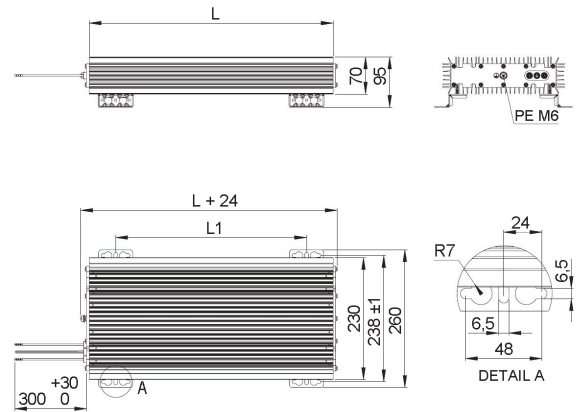

Cable connection IP50 type CBT-V..C..

P_n	Duty* 5/120	Vertical type CBT -	$L \pm 2$	$L1 \pm 2$	Weight (SiO2)	Resistance Range
kW	kW	IP50	mm	mm	kg	Ω
0.45	6	-V 180 C(H)(T) 0X1	180	70	3.1	0.04 - 13
0.58	10.1	-V 210 C(H)(T) 0X1	210	110	3.6	0.05 - 2000
0.83	17.9	-V 260 C(H)(T) 0X1	260	160	4.5	0.07 - 2000
1.35	27.5	-V 330 C(H)(T) 0X1	330	230	5.9	0.09 - 2000
1.65	37	-V 400 C(H)(T) 0X1	400	300	7.3	0.11 - 2000
1.9	48	-V 460 C(H)(T) 0X1	460	360	8.5	0.14 - 2000
2.3	58	-V 560 C(H)(T) 0X1	560	460	10	0.18 - 110
2.7	69	-V 660 C(H)(T) 0X1	660	560	12	0.22 - 130
3.2	82	-V 760 C(H)(T) 0X1	760	660	13.8	0.27 - 150
3.6	95	-V 860 C(H)(T) 0X1	860	760	16	0.31 - 180
4.1	111	-V 960 C(H)(T) 0X1	960	860	17.8	0.35 - 220

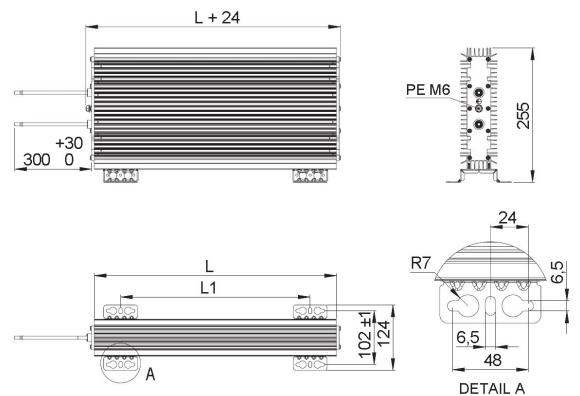

Box connection type IP20/IP21 CBT-H..D..1

P_n	Duty* 5/120	Type CBT -	$L \pm 2$	$L1 \pm 2$	Weight (SiO2)	Resistance Range
kW	kW	IP20/IP21	mm	mm	kg	Ω
0.45	6	-H 180 D(H)(T) 2X1	180	70	3.9	0.04 - 13
0.58	10.1	-H 210 D(H)(T) 2X1	210	110	4.2	0.05 - 2000
0.83	17.9	-H 260 D(H)(T) 2X1	260	160	5.1	0.07 - 2000
1.35	27.5	-H 330 D(H)(T) 2X1	330	230	6.7	0.09 - 2000
1.65	37	-H 400 D(H)(T) 2X1	400	300	8.2	0.11 - 2000
1.9	48	-H 460 D(H)(T) 2X1	460	360	9.2	0.14 - 2000
2.3	58	-H 560 D(H)(T) 2X1	560	460	11	0.18 - 110
2.7	69	-H 660 D(H)(T) 2X1	660	560	12.8	0.22 - 130
3.2	82	-H 760 D(H)(T) 2X1	760	660	14.6	0.27 - 150
3.6	95	-H 860 D(H)(T) 2X1	860	760	16.8	0.31 - 180
4.1	111	-H 960 D(H)(T) 2X1	960	860	18.6	0.35 - 220

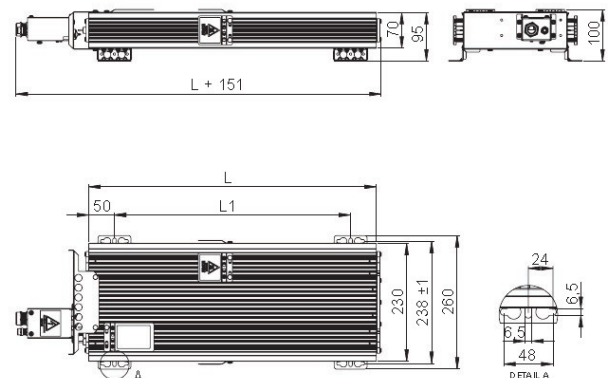

Box connection IP20 / IP21 type CBT-H ..G2.1

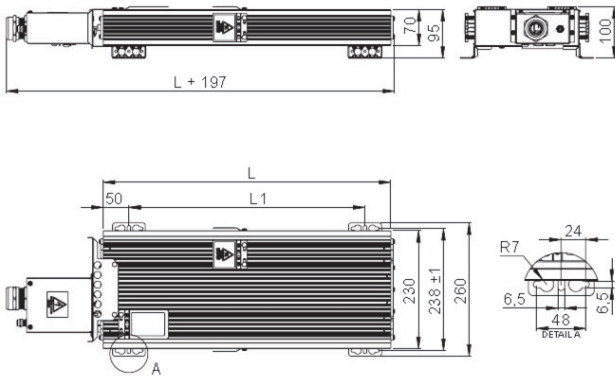

P_n	Duty* 5/120	Type CBT-	$L \pm 2$	$L1 \pm 2$	Weight (SiO2)	Resistance Range
kW	kW	IP20/IP21	mm	mm	kg	Ω
0.45	6	-H 180 G(H)(T) 2X1	180	70	3.9	0.04 - 13
0.58	10.1	-H 210 G(H)(T) 2X1	210	110	4.2	0.05 - 2000
0.83	17.9	-H 260 G(H)(T) 2X1	260	160	5.1	0.07 - 2000
1.35	27.5	-H 330 G(H)(T) 2X1	330	230	6.7	0.09 - 2000
1.65	37	-H 400 G(H)(T) 2X1	400	300	8.2	0.11 - 2000
1.9	48	-H 460 G(H)(T) 2X1	460	360	9.2	0.14 - 2000
2.3	58	-H 560 G(H)(T) 2X1	560	460	11	0.18 - 110
2.7	69	-H 660 G(H)(T) 2X1	660	560	12.8	0.22 - 130
3.2	82	-H 760 G(H)(T) 2X1	760	660	14.6	0.27 - 150
3.6	95	-H 860 G(H)(T) 2X1	860	760	16.8	0.31 - 180
4.1	111	-H 960 G(H)(T) 2X1	960	860	18.6	0.35 - 220

Box connection IP20 / IP21 type CBT-V ..G2.2

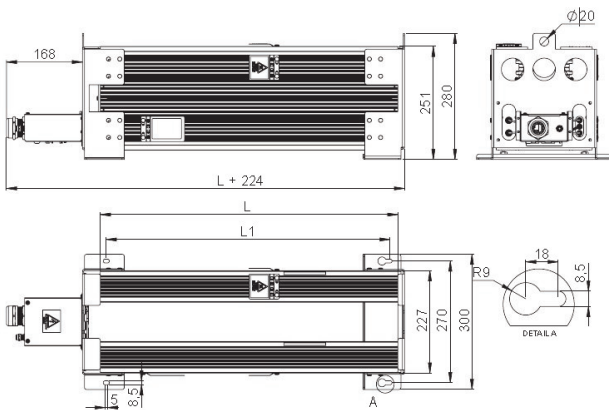

P_n	Duty* 5/120	Type CBT-	$L \pm 2$	$L1 \pm 2$	Weight (SiO2)	Resistance Range
kW	kW	IP20/IP21	mm	mm	kg	Ω
2.2	50	-H 400 G(H)(T) 2X2	400	300	18	0.06 - 1000
2.8	60	-H 460 G(H)(T) 2X2	460	360	20.5	0.07 - 1000
3.5	80	-H 560 G(H)(T) 2X2	560	460	23.5	0.09 - 55
4.2	95	-H 660 G(H)(T) 2X2	660	560	27	0.11 - 65
5.0	110	-H 760 G(H)(T) 2X2	760	660	30.5	0.14 - 75
5.5	125	-H 860 G(H)(T) 2X2	860	760	35.5	0.16 - 90
6.9	150	-H 960 G(H)(T) 2X2	960	860	39	0.18 - 110

Box connection IP20 / IP21 type CBT-V ..G3.3

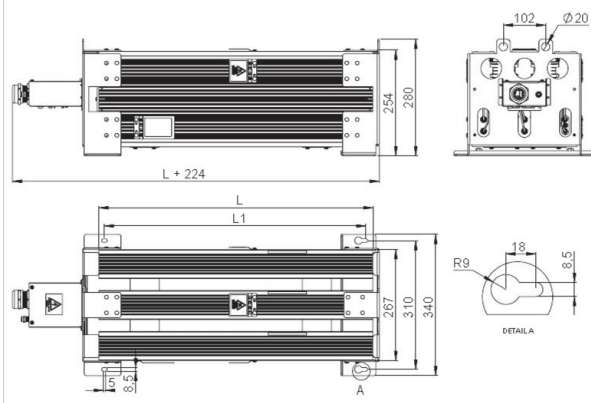

P_n	Duty* 5/120	Type CBT-	$L \pm 2$	$L1 \pm 2$	Weight (SiO2)	Resistance Range
kW	kW	IP20/IP21	mm	mm	kg	Ω
3.0	70	-H 400 G(H)(T) 2X3	400	300	25.5	0.04 - 1000
4.2	90	-H 460 G(H)(T) 2X3	460	360	29	0.05 - 1000
5.2	120	-H 560 G(H)(T) 2X3	560	460	33.5	0.06 - 35
6.3	140	-H 660 G(H)(T) 2X3	660	560	39	0.07 - 45
7.2	165	-H 760 G(H)(T) 2X3	760	660	44.5	0.09 - 50
8.0	185	-H 860 G(H)(T) 2X3	860	760	51	0.10 - 60
9.0	220	-H 960 G(H)(T) 2X3	960	860	57	0.12 - 70

Mechanical drawings

Box connection IP54 / IP65 type CBT-H ..B2.1

P_n	Pulse* 5/120	Type CBT-	$L \pm 2$	$L1 \pm 2$	Weight (SiO2)	Resistance Range
kW	kW	IP54/IP65	mm	mm	kg	Ω
0.41	6	-H 180 B(H)(T) 2X1	180	70	3.9	0.04 - 13
0.53	10.1	-H 210 B(H)(T) 2X1	210	110	4.2	0.05 - 2000
0.75	17.9	-H 260 B(H)(T) 2X1	260	160	5.1	0.07 - 2000
1.2	27.5	-H 330 B(H)(T) 2X1	330	230	6.7	0.09 - 2000
1.4	37	-H 400 B(H)(T) 2X1	400	300	8.2	0.11 - 2000
1.7	48	-H 460 B(H)(T) 2X1	460	360	9.2	0.14 - 2000
2.0	58	-H 560 B(H)(T) 2X1	560	460	11	0.18 - 110
2.47	69	-H 660 B(H)(T) 2X1	660	560	12.8	0.22 - 130
2.9	82	-H 760 B(H)(T) 2X1	760	660	14.6	0.27 - 150
3.3	95	-H 860 B(H)(T) 2X1	860	760	16.8	0.31- 180
3.6	111	-H 960 B(H)(T) 2X1	960	860	18.6	0.35 - 220

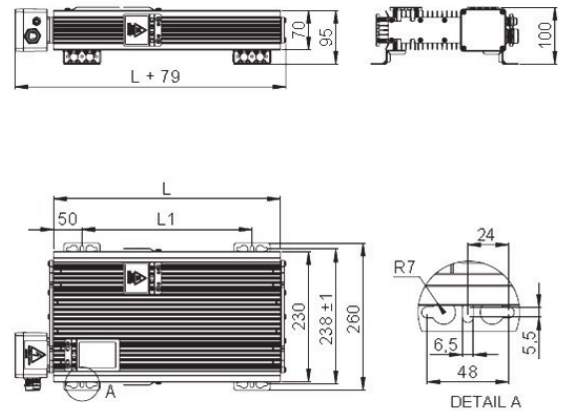

Box connection IP 54 / IP65 type CBT-V ..B2.2

P_n	Pulse* 5/120	Type CBT-	$L \pm 2$	$L1 \pm 2$	Weight (SiO2)	Resistance Range
kW	kW	IP54/IP65	mm	mm	kg	Ω
2.0	50	-H 400 B(H)(T) 2X2	400	300	18	0.06 - 1000
2.5	65	-H 460 B(H)(T) 2X2	460	360	20.5	0.07 - 1000
3.1	80	-H 560 B(H)(T) 2X2	560	460	23.5	0.09 - 55
3.8	100	-H 660 B(H)(T) 2X2	660	560	27	0.11 - 65
4.5	110	-H 760 B(H)(T) 2X2	760	660	30.5	0.14 - 75
5.0	130	-H 860 B(H)(T) 2X2	860	760	35.5	0.16- 90
6.2	160	-H 960 B(H)(T) 2X2	960	860	39	0.18 - 110

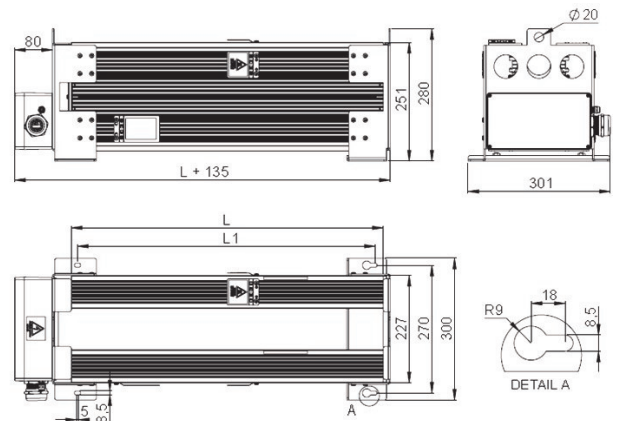

Box connection type IP 54 / IP65 CBT-V ..B2.2

P_n	Pulse* 5/120	Type CBT-	$L \pm 2$	$L1 \pm 2$	Weight (SiO2)	Resistance Range
kW	kW	IP54/IP65	mm	mm	kg	Ω
2.8	70	-H 400 B(H)(T) 2X3	400	300	25.5	0.04 - 1000
3.8	90	-H 460 B(H)(T) 2X3	460	360	29	0.05 - 1000
4.7	110	-H 560 B(H)(T) 2X3	560	460	33.5	0.06 - 35
5.7	130	-H 660 B(H)(T) 2X3	660	560	39	0.07 - 45
6.5	150	-H 760 B(H)(T) 2X3	760	660	44.5	0.09 - 50
7.2	170	-H 860 B(H)(T) 2X3	860	760	51	0.10- 60
8.1	195	-H 960 B(H)(T) 2X3	960	860	57	0.12 - 70

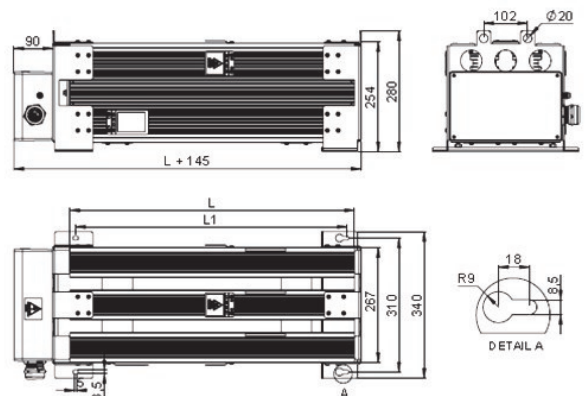

Box connection type IP54 / IP65 CBT-V ..B2.4

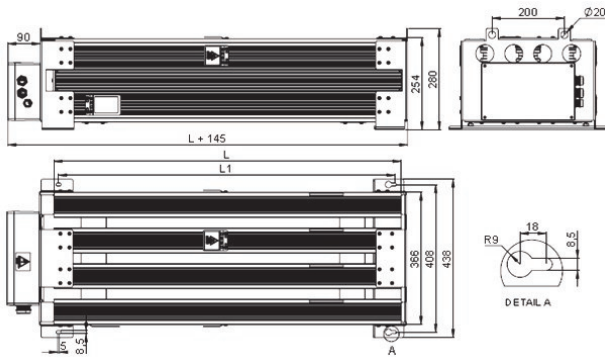

P_n	Duty* 5/120	Type CBT-	$L \pm 2$	$L1 \pm 2$	Weight (SiO2)	Resistance Range
kW	kW	IP20/IP21	mm	mm	kg	Ω
3.6	80	-H 400 B(H)(T) 2X4	400	300	25.5	0.36-460
5.0	110	-H 460 B(H)(T) 2X4	460	360	29	0.4-530
6.2	140	-H 560 B(H)(T) 2X4	560	460	33.5	0.5-33
7.6	170	-H 660 B(H)(T) 2X4	660	560	39	0.6-40
8.7	190	-H 760 B(H)(T) 2X4	760	660	44.5	0.66-50
9.8	210	-H 860 B(H)(T) 2X4	860	760	51	0.76-60
10.8	240	-H 960 B(H)(T) 2X4	960	860	57	0.86-60

connection boxes	IP rating	cable gland	clamping range	braid diameter (min.)	elec. connection
			[mm]	[mm]	[mm ²]
B-box (single housing)	IP65	M25	9-16.6	7.5	0.75-10
D-box	IP21	M25	9-16.6	7.5	0.75-10
G-box	IP21	M40	19-28	15	2.5-50
B-box (multiple housings)	IP65	M32	11-21	9	2.5-50
B-box (multiple housings)	IP65	M40	19-28	15	2.5-50
thermal switch (optional)	-	M12	3-7	-	0.5-4

Other cable gland sizes on request

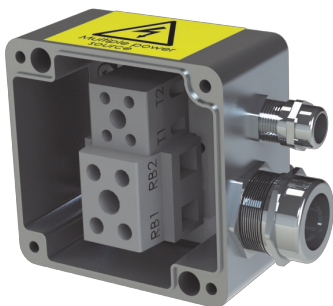

B-box
Single-body

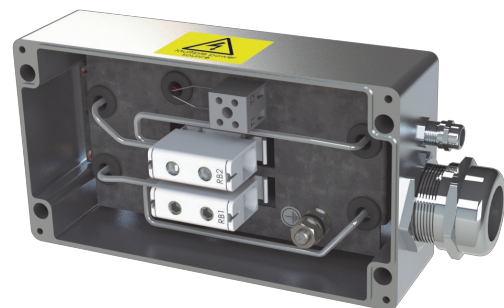

B-box
Multiple-housings

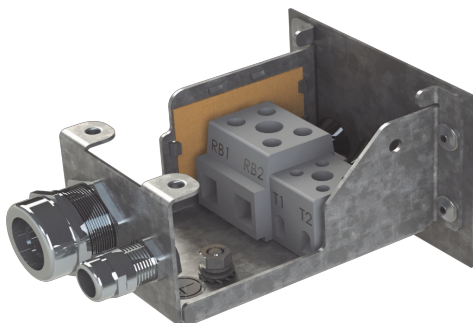

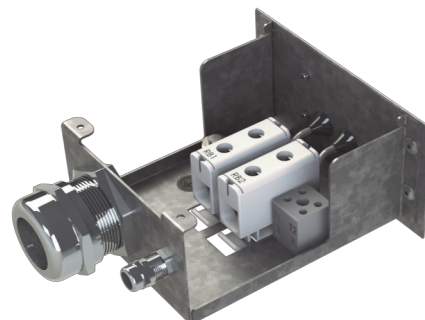

D-box

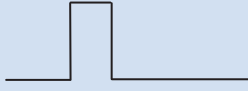

G-box

Pulse load table

CBT-H Cx(T)	Square pulse each 120 seconds, ambient temp. = 40°C									
		duty 1 second [kW]	Max temp. [°C]	duty 5 second [kW]	Max temp. [°C]	duty 10 second [kW]	Max temp. [°C]	duty 20 second [kW]	Max temp. [°C]	duty 40 second [kW]
CBT-H 180 15R	18.4	110	5.1	140	3	160	1.9	180	1.1	220
CBT-H 210 100R	24.7	110	6.1	130	3.8	150	2.5	190	1.7	240
CBT-H 260 60R	44	130	10.7	150	6.4	180	4	210	2.7	270
CBT-H 330 40R	71	140	22	190	13	220	8	260	4.3	280
CBT-H 400 30R	105	160	30	210	18	250	10.7	290	5.4	280
CBT-H 460 20R	128	170	36	220	21	250	12	290	6.2	290
CBT-H 560 15R	190	200	50	250	28	280	15	300	7.6	300
CBT-H 660 14R	257	230	64	270	36	300	18	300	9.2	310
CBT-H 760 12R	315	240	78	290	43	310	21.5	310	10.7	310
CBT-H 860 10R	370	250	89	300	50	320	25	320	12.4	320
CBT-H 960 9R0	480	290	110	330	56	330	28	330	14	330
	Triangle pulse each 120 seconds, ambient temp. = 40°C									
	duty 1 second [kW]	Max temp. [°C]	duty 5 second [kW]	Max temp. [°C]	duty 10 second [kW]	Max temp. [°C]	duty 20 second [kW]	Max temp. [°C]	duty 40 second [kW]	Max temp. [°C]
CBT-H 180 15R	39	110	10.7	140	6.3	160	3.8	190	2.3	220
CBT-H 210 100R	50	110	12.7	130	7.7	150	4.9	180	3.2	230
CBT-H 260 60R	90	140	22	160	13	180	8	210	5	250
CBT-H 330 40R	148	140	46	200	27	230	16	260	8.5	280
CBT-H 400 30R	217	160	63	220	37	250	21	280	10.6	280
CBT-H 460 20R	265	170	74	230	44	260	25	290	12.3	290
CBT-H 560 15R	390	200	103	260	58	290	30	300	15	300
CBT-H 660 14R	530	230	134	280	73	310	37	310	18	310
CBT-H 760 12R	645	240	160	290	86	310	43	310	22	310
CBT-H 860 10R	578	260	183	300	98	320	50	320	25	320
CBT-H 960 9R0	983	290	226	330	113	330	57	330	28	330

The table above shows pulse power ratings for typical resistor sizes/lengths and typical Ohm values.

Pulse load

The ability to withstand pulse-loads varies according to resistor size, length and diameter of the internal resistor wire. As such, it is impossible to create standard graphs that would apply to all customer applications. In some cases, the load-profile will be the combination of a square and a triangular pulse, such as is the case with Low Voltage Ride Through (LVRT) and Emergency Brake situations, as encountered in the Wind Power industry.

On request, Danotherm performs simulations based on the actual application and for guidance, has produced tables for various load-profiles for resistors with standard wire. The above table shown is based on a resistor with indicated ohm value and standard wire thickness. Depending on the application, resistor construction can be adapted to optimally match the application. In the tables above, the peak powers of trains of rectangular and triangular pulses of 120 second periods are shown for durations of 1 to 40 seconds.

Ingress Protection

The Ingress Protection rating (IP) value depends on the resistor and on the connection style. The basic IP rating for resistors is IP 50 but by the addition of gaskets, they can be increased to IP 54 or IP 65 which is also possible for resistors with flying leads. For resistors with connection box type B, the maximal IP value is 65. Resistors with connection boxes D and G have an IP 21 rating when mounted vertically and IP 20 when mounted horizontally.

IP values and their type-tests are well defined; for instance "IP 65" means dust cannot penetrate the box or if dust occurs internally, it will not influence the electrical properties. It should be able to withstand water jets from any direction with a certain pressure during 3 minutes; however, it does not mean that it can withstand continuous rain. If the resistor is used outdoors, then it should be protected against direct rain.

IP 65 rated resistors can be cleaned with a high pressure hose, but this can only be done when the resistor has cooled down to the ambient temperature, otherwise the water will cool the housing causing a partial vacuum inside, drawing in water.

Danotherm offers standard solutions for one to four cases combined into one compact configuration with pulse-withstand capability of 1MW (5MJ) and also OEM versions with a maximum of 20 resistors. Depending on the electrical connection, the IP class ranges from IP 00 to IP 65. Connections can be via a terminal box, DIN-rail terminals or cable lugs. These resistor types are also offered in high voltage versions and with higher ohmic values.

The salient features of Alpha resistors are that they have:

- Small dimensions
- Cool surfaces in operation
- High pulse-load capabilities
- High vibration capabilities
- No external electrically-live parts
- High IP classes
- Fail-safe capabilities (on request)
- low noise levels.

Ω NIBE

Danotherm Electric A/S
is a NIBE company

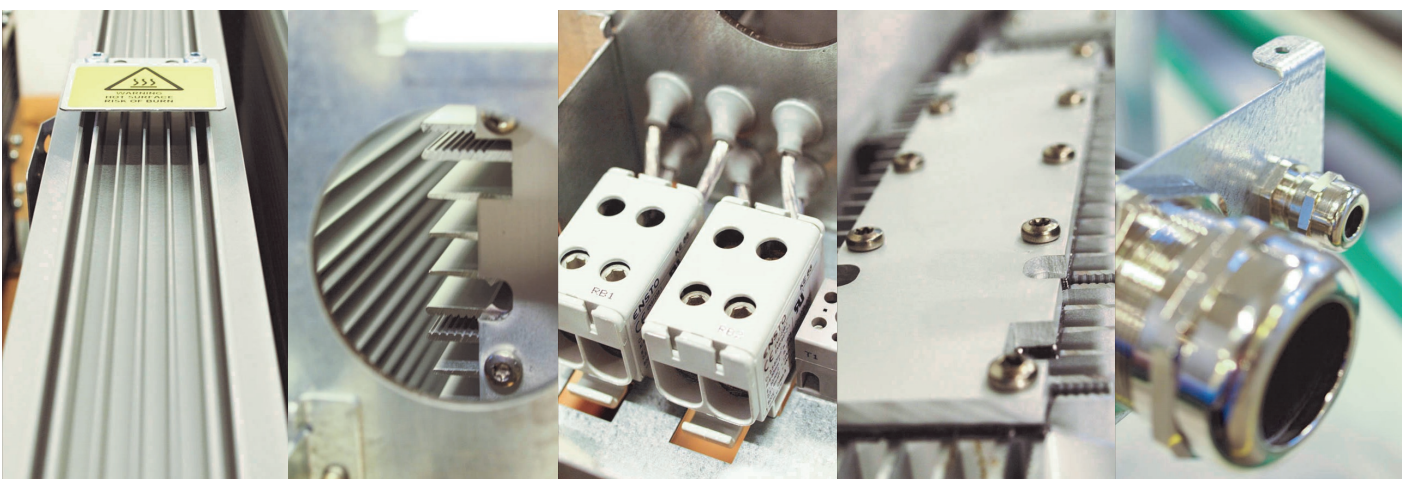

Danotherm has developed a thermal simulation method by which it is possible to optimize a resistor to a specified application. This gives following benefits

- Short and fast engineering time, saving engineering costs
- Simulation software for electrical circuits can be used for thermal simulations (PSpice, Matlab, Plecs or any other)
- Simulations can be done by the customer or if requested by Danotherm
- Simulation is based on customers application, any electrical circuit that can be simulated can be used
- For more complex loads a data file (like csv) can be used for input
- Optimizing the design, reducing overall size and costs
- Proof of capability is given without even building and testing samples

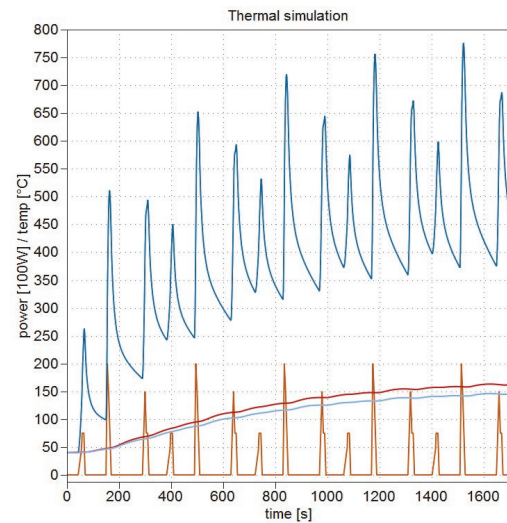
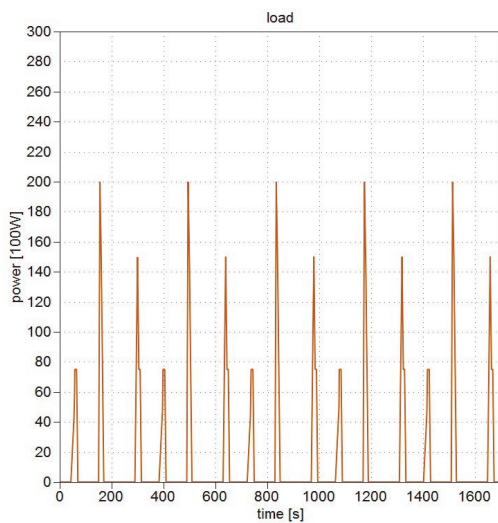
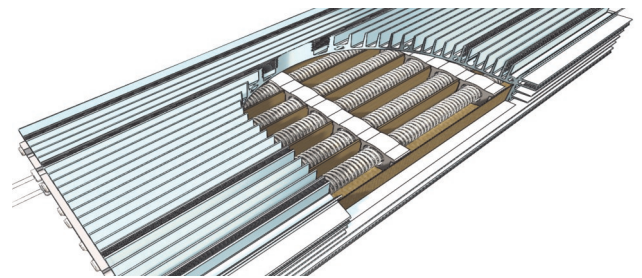
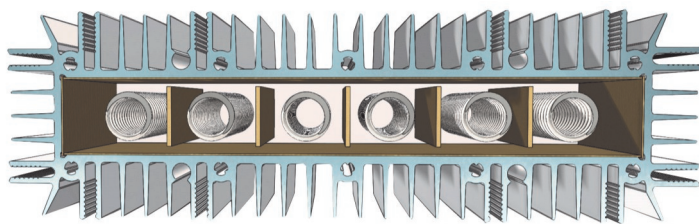

Measured on site: Brake Power stored in .csv file.

Other possibilities could be a description of a typical or worst case brake pulse and a repeat cycle.

Simulation made by Danotherm

Results of temperature simulation of specified load in a suggested resistor type.

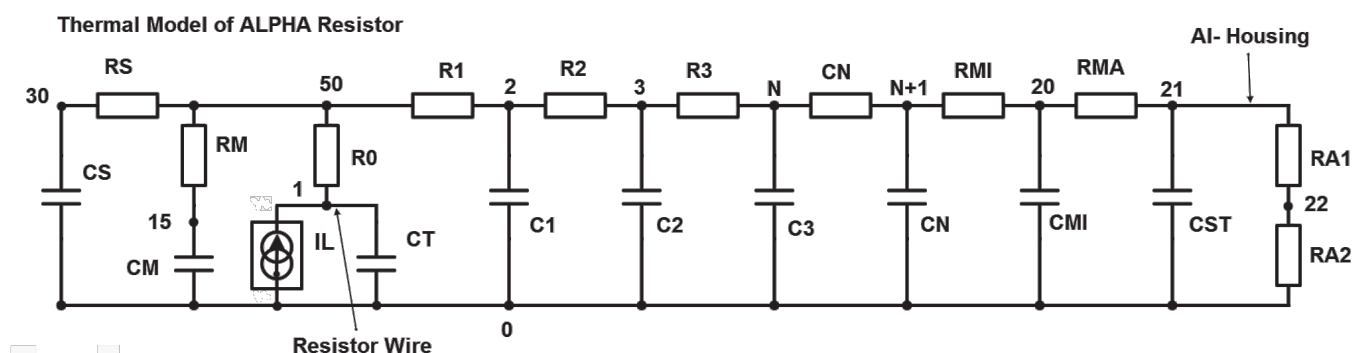

Danotherm resistors are used as:

- Pre-charge for DC-link (super) capacitors
- Pre-magnetization of power transformers
- Brake resistors for industrial drive systems
- Emergency stops in (gas) turbines

Danotherm resistors are used in:

- Elevators
- Escalators
- Cranes
- Vessels
- Wind turbines
- (Trolley)busses
- Trams / Metros / Trains (auxiliary circuits)
- Conveyer belts
- Transformers
- Turbines
- Excavation machines

Danotherm supports your request. The very start is your specification of the application, the load and environmental conditions. Ideally, a power-time graph is presented which forms the basis of the thermal simulation. If such graph is not available, the electrical circuit of the application is build in the simulation software. It is also possible to use a data file as input for the load. Such file can be build by measurements on the site or they come from another simulation software program.

The next step is to feed the generated power losses into the thermal model. Each resistor which its physical properties has its own, unique, thermal model. With the simulation the temperatures inside the resistor and of the outside housing surface, are simulated. Here, the maximum temperature values are observed and at the same time care is taken not to over dimension the resistor.

When the type and internal construction of the resistor is defined, the resistor will be further tailored to the customers needs. Connection boxes, connection cable sizes, cable glands, IP ratings, mounting brackets, metal surface treatment, auxiliary circuits, such as PT100 sensors and thermal switches, are all considered.

Finally, packing and shipping is an important topic. The resistors should be safely packed to prevent damage during transport and at the same time the costs for shipping and packing must be considered. Together with our customers the best option is chosen.



Overview of the ALPHA resistor family (IP00-IP65)

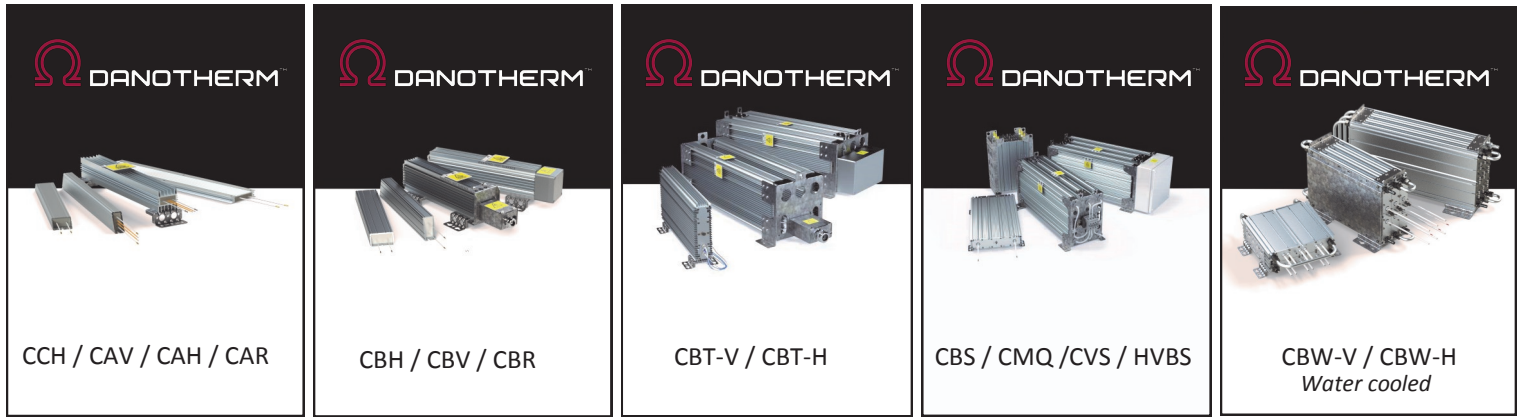

Power: 60-410W	Power: 85W-1.7kW	Power: 410W-12kW	Power: 445W-15kW	Power: 860W-25kW
	9-150kJ @5s	25-550kJ @5s	80kJ-2.5MJ @5s	6.4kJ-1.1MJ @5s
- Applications				
Charge / Discharge	High Pulse load	High Pulse load	High Pulse load	Short recovery time
Brake	Brake	Brake	Brake	Brake
Filter	Filter	Filter	Medium voltage	Filter
	Charge / Discharge	Charge / Discharge	Charge / Discharge	High Pulse load

Other resistor types from Danotherm (IP00-IP66)



Multi purpose	Outdoor & Marine	Filter	Medium & High voltage	Filter & load
Power: 100W-5kW	Power: 1-500kW	Power: 4-200kW	Power: 500W->	Power: 5kW-1MW
Ceramic wirewound	Steel tube	Wirewound	Steel grid	Steel tube

CBT-H 400 CH(T) 2 8 1 22R KT

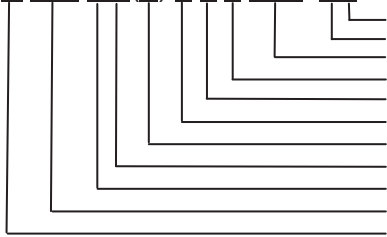

Last digits > 400: Customer specific version, otherwise:
 Thermal drift; standard T=100ppm
 Tolerance; standard K=± 10%
 Ohm value (Example 2R2=2.2Ω / 22R = 22Ω)
 Number of case style housings (1, 2, 3 or 4)
 Thermal switch temp; 5=130°C / 6=160°C / 7=180°C / 8=200°C
 0=cable connection, 2=connection box type
 T=Thermal switch (normally closed)
 Wire element (TBD by Danotherm)
 Connection: C=no box / D=IP20 / B=IP65 box
 Length of resistor housing in mm
 H=horizontal mounting feet / V=vertical mounting feet

Danotherm Electric A/S
 Naesbyvej 20
 DK-2610 Roedovre
 Denmark
 CVR 1012 6061
 DAN EN 16.5040.R7
 6June2017

