

NIBE ELEMENT
WIND SOLUTIONS



NIBE ELEMENT WIND SOLUTIONS

RELIABILITY · ENERGY EFFICIENCY · SUSTAINABILITY

NIBE ELEMENT

EVERYDAY · EVERYWHERE

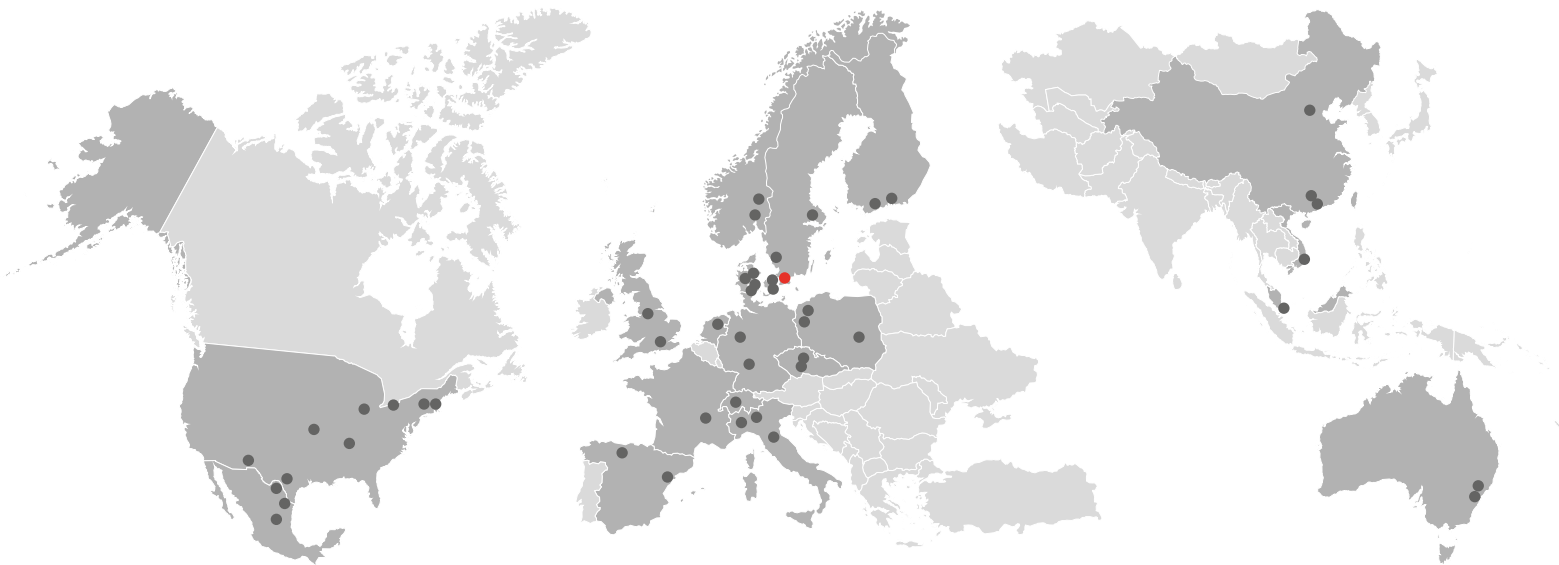

NORTH AMERICA

EUROPE

ASIA/OCEANIA

NIBE ELEMENT

NIBE Element develops, produces and sells customized solutions and components for intelligent heating and control. The original technology was stainless steel tubular heating elements. However, the constant growth of the Group, both organically and through acquisitions, has enabled the integration of several new technologies. Today the Group offers a far wider product range, with a vast number of technologies for several industry sectors and a large variety of applications.

- 9000 employees and 60 production units on 4 continents
- 70 years of accumulated competence and experience in the industry
- International organization with local presence
- Many specialized R&D departments to bring new innovative solutions to the market
- Customized solutions fulfilling special requirements
- Strong focus on components and systems for sustainable energy solutions
- Volume and industry production in different parts of the world

TECHNOLOGIES

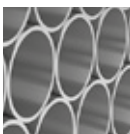

Tubular Heating Elements

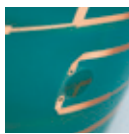

Printed Elements



Supported wire Elements



Measurement & Control



PTC Elements

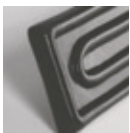

IR & Halogen Elements



Heating Cables



Suspended Wire Elements



Heat Pump Technology

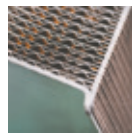

Special

INDUSTRY SECTORS



Industrial/
Projects



Energy/
Environment



Advanced
technology



Commercial
equipment



Home
appliance



Transportation



HVAC

NIBE ELEMENT WIND SOLUTIONS

WORLD WIDE REPRESENTATION

COMPONENTS AND TECHNOLOGIES FOR WIND TURBINES

NIBE ELEMENT WIND SOLUTIONS is a cooperation of companies within NIBE ELEMENT that provides components and technology for wind turbines.

At NIBE, we believe that our combination of global representation and individual, local manufacturers brings us closer to our customers. We manufacture products that contribute to more efficient use of energy and reduced carbon dioxide emissions. Energy, climate, and sustainable development are high on the agenda for us, and we continually work to improve our existing product range and develop new, innovative products and solutions.

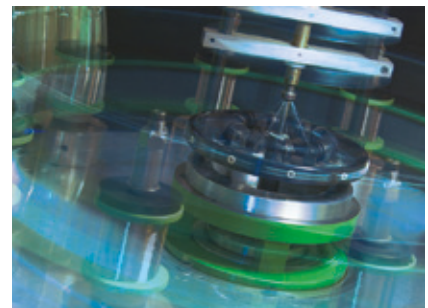

EASY ACCESS TO THE BEST SOLUTIONS

NIBE ELEMENT WIND SOLUTIONS

NIBE ELEMENT WIND SOLUTIONS strives to supply the highest quality products combined with a flexible way of working, throughout the process, all the way from sales, product development, manufacturing, and logistics. We provide products meeting all relevant standards and tests, certifying products according to customer specifications.

Also, we are able to carry out tests for our customers in modern labs, constantly improving our product performance.

Heating equipment for cold climate	4
Portable heating blanket controller (PHBC)	6
Heating blankets for PHBC systems	8
Heating blankets	9
Nacelle fan heaters	11
Anti/De-icing	12
Immersion heaters	14
Heating of fluids, glycol and hydraulics	15
Power resistors	16
Resistor applications	17
Electrical components for automation	18
Anti condensation heaters	19
Temperature sensors	20
Cartridge heaters	21
Silicone heaters	22
NIBE ELEMENT WIND SOLUTIONS	23



Loyal, Sinus JEVI, Strukturgruppen, Calesco, Eltop, Heatrod, Springfield Wire, Innotek, Meyer, Askoma, IC Electronic, Marathon Heater, Termorad, Hyper, Heatron, Ormandy Electric, ATE Electronics, Braude, Omni, Hotwatt, Backer AB.

Less downtime with electrical heating and energy dump resistors

NIBE ELEMENT WIND SOLUTIONS wishes to make it easy for our potential customers, existing customers, and partners to get high quality solutions for a wide spectrum of heating related wind turbine applications.

We offer design, production, and supply of electrical heating and resistors for the wind turbine industry. Production in Europe, America, and Asia.

OBSTRUCTION LIGHT SYSTEM

Silicone heaters

EMERGENCY LIGHT SYSTEM

Silicone heaters

CONTROL PANEL

Energy dump resistor
Filter resistor
Charging resistor
Silicone heaters
Temperature sensors
PTC Fan heaters

NACELLE FAN HEATERS

GENERATOR

SLIPRINGS

Temperature sensors

HYDRAULIC UNIT FOR BRAKES

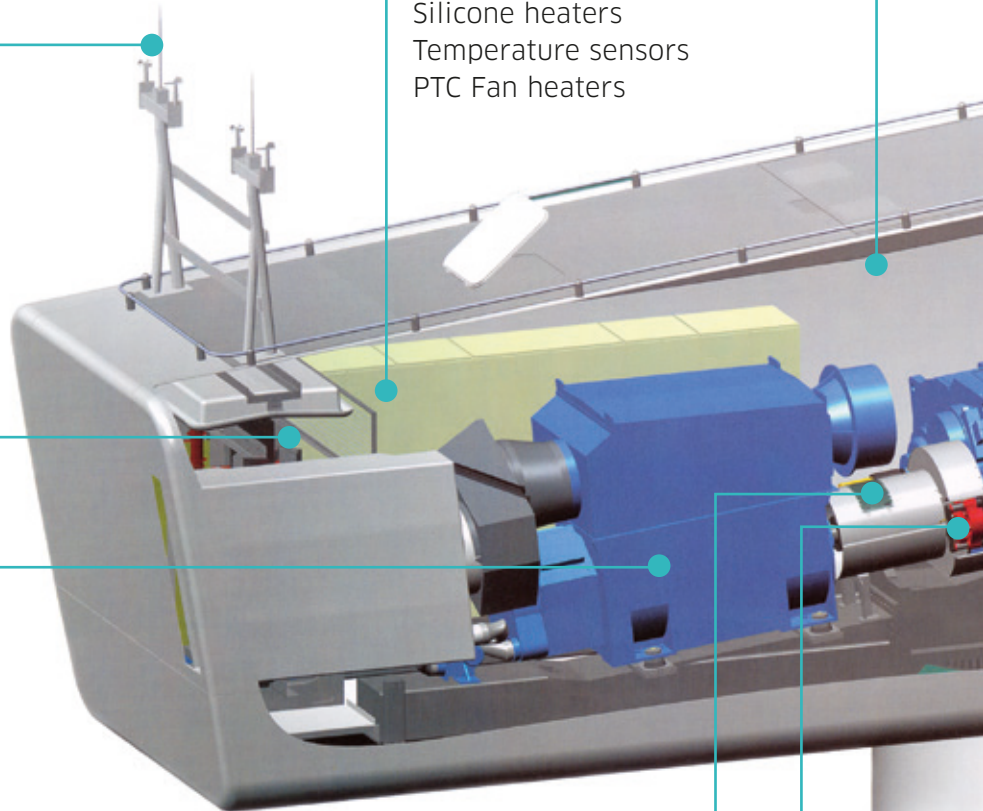

GEAR BOX

Immersion heaters
Tubular heaters
Submersible heaters
Pressure- and temperature sensors

LUBRICATION SYSTEM

Heating cable/tracing
Immersion heaters

DE/ANTI-ICING SYSTEM

Customized plug and play system

PITCH ELECTRICAL SYSTEM

Silicone heater for battery box

PITCH HYDRAULIC SYSTEM

Silicone heater for bladder accumulator

HYDRAULIC UNIT

Immersion heaters

PIPES

Tracing cable

TOWER

Nacelle fan heaters

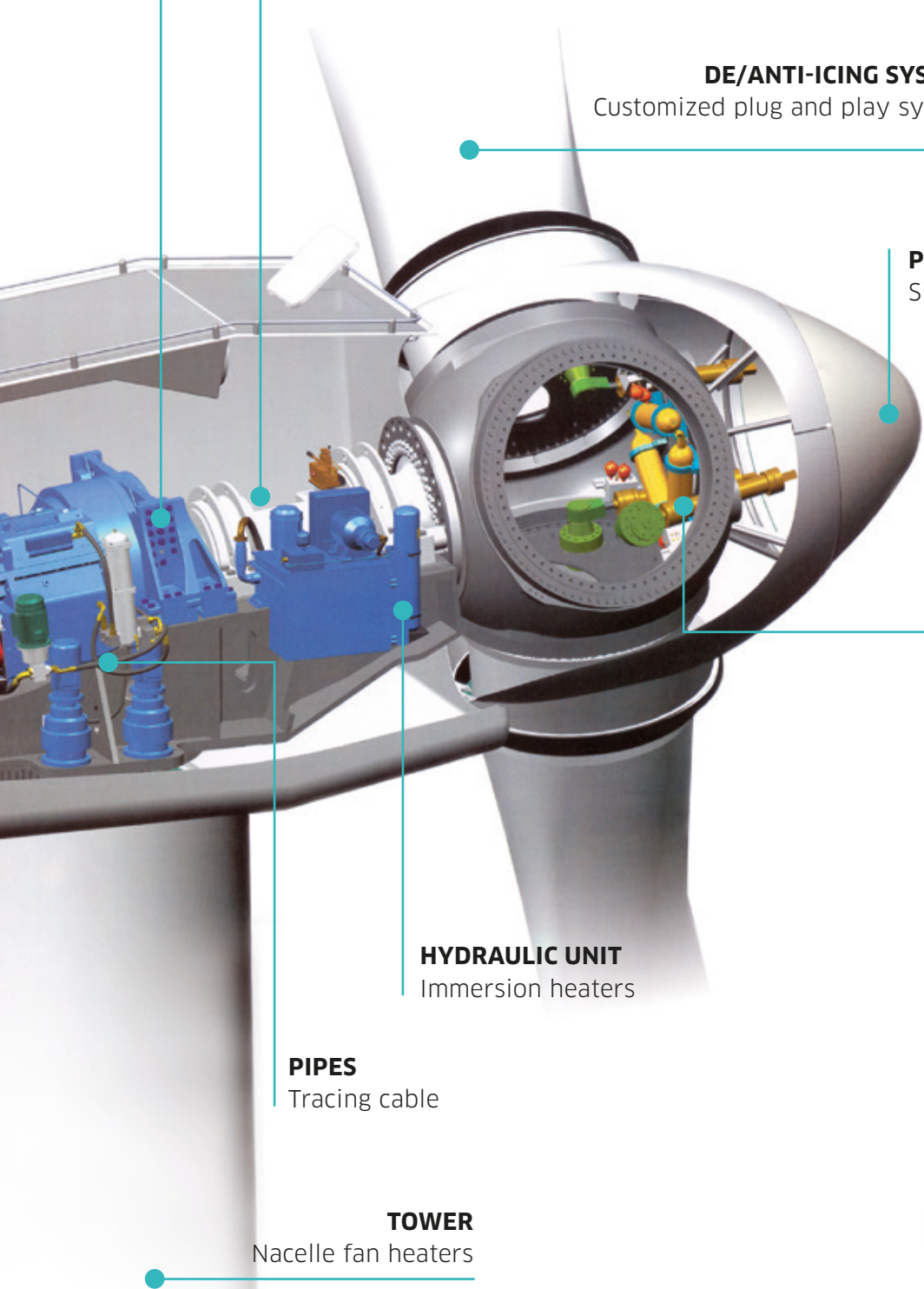

Unique repair control

To ensure correct overhaul and maintenance of wind turbines and their blades and to reduce maintenance downtime, NIBE ELEMENT WIND SOLUTIONS has developed and designed a solution that permits the blades to remain warm during the repair period.

The concept is based on a portable intelligent controller that is combined with heating jackets.

The unit named PHBC-6 (Portable Heating Blanket Controller), controls the temperature via built-in sensors in the heating jacket.

At the same time, the PHBC-6 also measures and logs the ambient temperature and humidity.

All management and control of temperature, data, alarms, trend curves, and programmed planning time is handled via a handheld tablet.

The screen layout involves a step-by-step solution, with each step requiring confirmation before proceeding to the next level. This is to ensure that the operators are aware of what needs to be done in each step and what needs to be logged before proceeding to the next level.

PHBC-6 is developed in close cooperation with some of the most skilled composite engineers in the turbine blade maintenance business and the manufacturer of heating blankets.



- Perfect curing
- Full curing support
- The right TG value instantly
- Best repair quality
- Automatic curing control





The idea behind the PHBC-6 is:

- To secure a proper repair each time, without any failures like too hot or too cold curing.
- To higher the quality of repairs and curing by reaching the correct Tg value each time in the first go.
- To avoid mistakes of monitoring curing temperatures over time.
- To decrease down time for the turbine, due to the fact, that repairs are perfect every time.
- To be able to start up, more than one repair job per turbine per day.
- To be able to supply an automatically generated and full documented report to the customer.
- To let the PHBC-6 work, as long as the maintenance people do something else.
- To monitor and control the curing process from another place.
- To communicate wireless between operator and PHBC-6.
- To reduce and save time in most aspects of the repair / curing.
- To be more reliable in the repair process



Antenna for serial communication between several PHBC units.



Perfectly controlled curing - everytime

The use of heating blankets are often related to the knowledge of how the material of the blade reacts in different environments as well as the construction and design of the blade.

NIBE ELEMENT WIND SOLUTIONS has during many years worked closely together with some of the most professional and skilled composite engineers in this field. It has given us a lot of experience of where the heating blankets are used during the curing process.

Each application is different, and therefore NIBE ELEMENT WIND SOLUTIONS can offer a customized heating blanket which exactly fits the customer application. In cooperation with our customers, we are able to calculate the power density of the heating blankets. As a result, the curing process ends up with a perfect Tg value (glass temperature), each time.



All our heating blankets can be delivered with or without built-in limiters to protect the heating blankets against overheat, as well as an adjustable thermostat to control the temperature of the blankets.

If you want to use our heating blankets with the new intelligent control system, PHBC-6 mentioned on page 5 and 6, you do not need a thermostat, because the heating blankets have built-in Pt100 sensors beneath the silicone path, to scan the temperature and use it in the control system.

After finished curing, a full report can be generated.



We cover it all...

NIBE ELEMENT WIND SOLUTIONS heating blankets for heating the edges of wind turbine blades.

Due to low weight and flexibility, heating blankets are the obvious choice for on-site repair use. All our heating blankets can be customized. Once the leading and trailing edge have been cured, ground, and polished, any procedures required can be carried out without any risk of grinding non-cured material and thus releasing hazardous substances into the atmosphere.



Can be customized to fit your request!

May also be manufactured for use elsewhere on the blade.

The blankets may also be designed for use on **various parts** of the blade. For repair use **on-site**, they are just great due to low weight and flexibility.





Specially designed for harsh environments

The NIBE ELEMENT WIND SOLUTIONS fan heater is a rigid and reliable fan heater designed for harsh weather and rough environments wherever best quality materials and high performance are required.

The fan heater will perform superbly down to -40°C , as well as in high altitude. This heater is thus the perfect choice for high quality wind turbines in cold climate environments.

This technology has been applied successfully for more than 15 years. Ongoing development allows for these products to continue to perform as quality units in the next generation of turbines.



Delta fan heater designed for harsh weather and rough environments. 240, 600V, 9kW. UL approved.



Fan heaters for frost protection in wind turbines.



Delta fan heater from 100V...690V...3-21kW. Various bracket systems as option.

UL APPROVAL

The Delta fan heater from NIBE ELEMENTS WIND SOLUTIONS is either available as standard CE or with UL/CSA approval.



CUSTOMIZED CENTRIFUGAL FAN HEATER

Fan heater for nacelle heating

- Heaters are available from 3-21kW as standard units
- From 110V...690V
- UL approved types in the range of 240V...600V and max. 9kW.

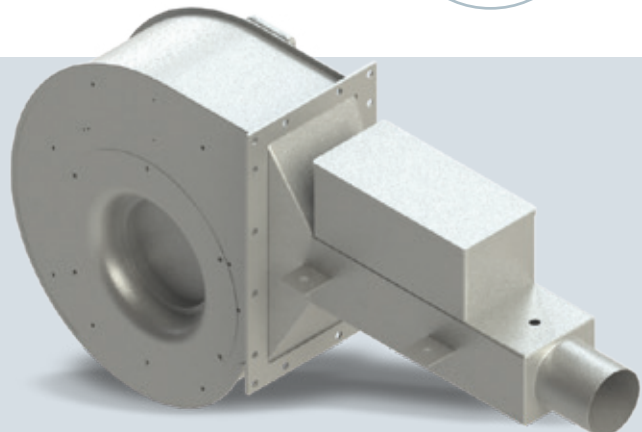

We are in control of the **Anti/De-icing** process

The anti-/de-icing units we have developed and manufactured are an effective solution for wind turbines placed in cold climate. The complete anti-/de-icing unit will prevent icing effects on your rotor blades and avoid down time of the wind turbine. The unit can be operating irrespectively of the wind turbine itself being on or off.

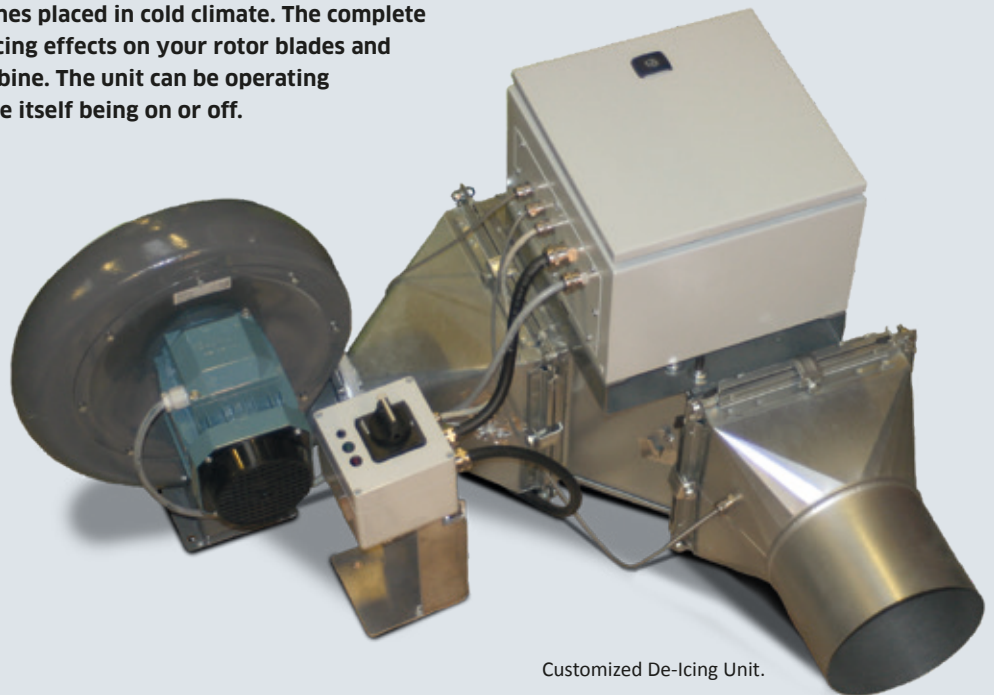

Customized De-Icing Unit.

Design and construction

Development:

- Blade construction
- Layout
- Blade specification
- Pipe construction inside blade

Specification for De- & Anti-Icing unit:

- Power
- Air pressure
- Air flow
- Corrosion class

Design & Construction:

- According to development and specification steps

Prototype:

- Vibration test
- Function test
- Performance test



Education and support

Support at client:

- Education
- Installation support
- Test

Commissioning on-site:

- Education
- Technical support
- Spare parts for commissioning

Service in operation:

- Spare parts package for 5 years operation
- Technical support

Serial production

- we can produce / supply:

- Heater
- Blower
- Controller
- Bracket
- Piping (2nd supplier)

Largest product range of immersion heaters with UL



ALL OUR IMMERSION HEATERS ARE:

- available in required voltage, power and length, with flange or thread.
- available in materials according to request.
- designed to comply with requirements and specifications for products used on wind turbines.
- essentially used for heating and maintenance of oil and lubricating systems e.g. in gear boxes and hydraulic vessels.
- rapidly replaceable and almost without any use of tools, and furthermore the oil does not need to be drained.

UL APPROVAL

Almost all the immersion heaters from NIBE ELEMENT WIND SOLUTIONS are available either as standard types or with UL/CSA approval.

We offer a comprehensive product range of immersion heaters with UL/CSA approval, which is second to none world wide.



EAC

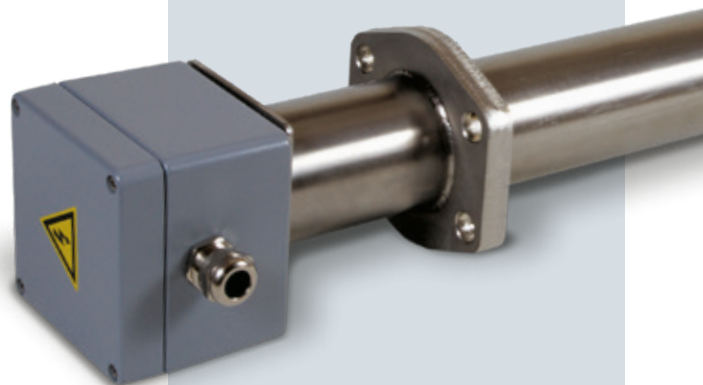

Heating of fluids, glycol and hydraulics



External flow heater

External flow heater with motor, pump, and expansion valve. For heating of lubricating oil in gearboxes, e.g. in arctic areas where additional heating is required. The built-in pump circulates the lubrication oil through the gear box. The flow heater is equipped with a pump, temperature limiter, and Pt100 sensor. ETL approved.



Submersible oil heater

Submersible oil heater intended for preheating of hydraulic oil before start-up to minimize system wear. The preheating also reduces traces of water in the tank. Easy to use in existing oil tanks, there is no need for permanent installation. The oil heater is fastened at the bottom of e.g. the oil tank with integrated magnets.



Immerge heater

Immerge heater for hydraulic oil with magnets for fixation 2000W - 3x690V - 1W/cm². Available in other voltages and wattages upon request.



Glycol heaters

Glycol heaters are used for pre-heating of cooling water in the cooling/heating system in converters in wind turbines before start-up of the wind turbine.

Tank heater

Tank heater for hydraulic oil.

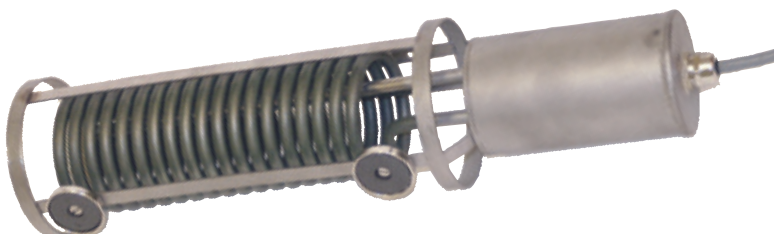

The **glycol heaters** are available in various materials and designs to meet customer requirements.

Power resistors in modern wind turbines

Our programme includes traditional wire-wound resistors, steel grid resistors, the most advanced insulated high pulse load aluminium housed resistors and steel tube resistors also for high voltage applications.

The resistors are available with UL/CSA approval. 

Below are examples of resistors in the power train of a modern wind turbine.

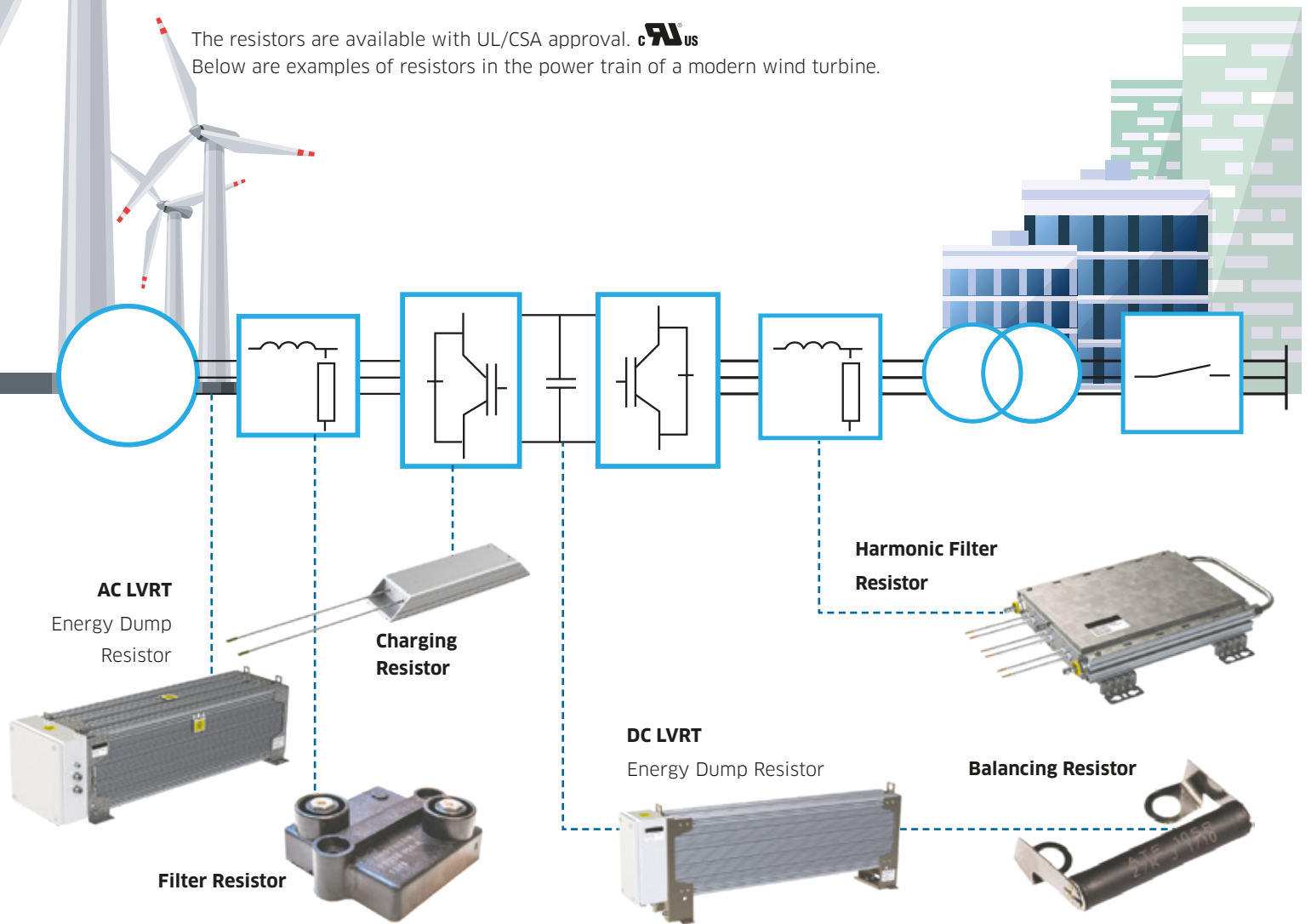

THE RESISTORS ARE USED AS:

- High energy dump resistors
- (Harmonic) Filter resistors
- Brake resistors for pitch control
- Charging and de-charging resistors
- Balancing resistors

WE OFFER:

- Traditional wire-wound resistors
- Steel grid resistors
- Water cooled steel tube resistors
- Aluminium housed high pulse load resistors
- Thick film resistors

Resistor applications in modern wind turbines



LVRT, High energy dump resistor

LOW VOLTAGE RIDE THROUGH

is the situation where the wind turbine is not able to feed the generated energy into the grid. If the grid fails during a short time, part of the generated energy needs to be dissipated. When the grids come back on, the wind turbine can continue producing energy.

PITCH CONTROL BRAKE RESISTORS

are used to brake the movement of the turbine blades when their position is changed. During braking the re-generated energy is dissipated in a resistor.

CHARGING AND DE-CHARGING RESISTORS

safely charge and de-charge the DC-link bus in the wind turbine inverter.

FILTERS AND CROWBAR RESISTORS

Filters improve the quality of the electrical generated energy. Crowbars take out the voltage peaks that occur from time to time in the system and protect the electrical/electronic systems.

Our resistors are standard or customized and available with UL/CSA approval.

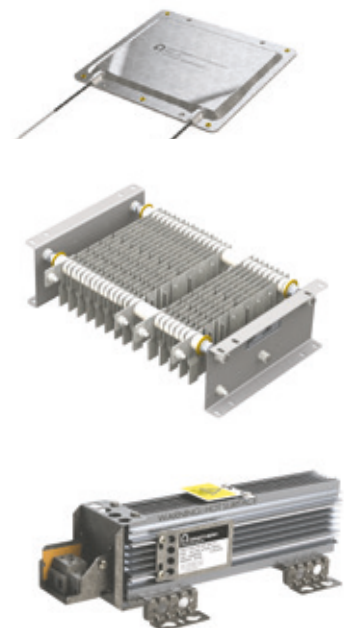

Soft starters for full-speed applications

The STL and SMC series will reduce common problems associated with motor starting and stopping, such as electrical surges, spikes and high inrush currents. Additionally, it will also address problems associated with mechanical stress and wear.

Yaw System application for turning the nacelle.

Turning of the nacelle has to be extremely reliable; The soft starters reduces the high inrush currents and mechanical stress on the Yaw-Motors. Increasing the lifetime of the system and reducing downtime.

Despite being cost efficient, the components offer a very long lifetime due to its unique semiconductor design. A true fit-and-forget product.



STL 3 START TORQUE LIMITER

1/3 phase motor applications

- Start Torque Limiter (Soft-Starter) suitable for motor applications up to 25 A.
- Suitable nominal voltage range 208-690V AC +/- 10%
- Adjustable ramp up time from 0,5 to 5 sec.
- Adjustable start torque from 0-85%.
- Up to 22 kW load on just 45mm width, can be mounted side by side.
- 1-phase control.



SMC3 SOFT STARTER

for 3 phase motor applications.

- Soft starter suitable for motor applications up to 100 A.
- Suitable nominal voltage range 208-600V AC
- 2 or 3-phase controlled
- Adjustable ramp up time up to 30 sec, ramp down 60 sec.
- Initial torque adjustment with kick-start.
- Integrated by-pass relay or external by-passing output terminals available
- Modular design 22,5 mm / 45mm / 90mm / 180mm - can be mounted side by side.

Heating for electrical control panels

Condensation forms due to fluctuating temperature, even in sealed enclosures. In combination with dust and aggressive gases, condensation causes corrosion resulting in stray currents and arcing. Too high temperature, or for that matter a too low temperature, may also lead to serious component failure. The safety risk is enormous, and the cost of operational delays as a consequence is incalculable.

As a supplement to our product range in anti-condensation, we are also in a position to offer a new filter fan series in EMC and standard versions with excellent performance and shielding characteristics as well as panel lighting and accessories.

Anti condensation heaters for cabinets with electronic thermostat.

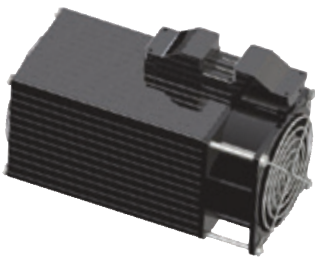

Fan filter units in various versions with and without fan.



Anti condensation heaters for cabinets with three power settings and independent fan circuit to aid climate cooling.



Anti condensation heater, mounted on a galvanized bottom plate, and covered by a stainless steel protection grate.

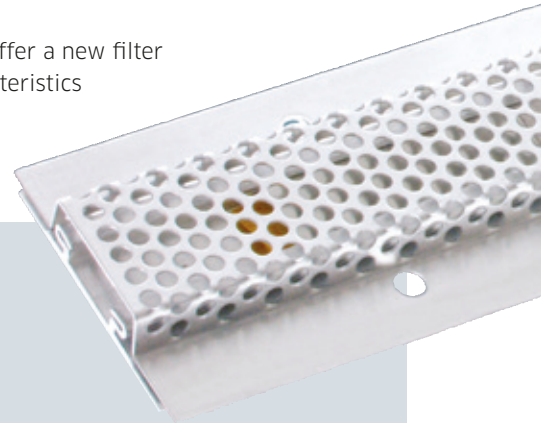
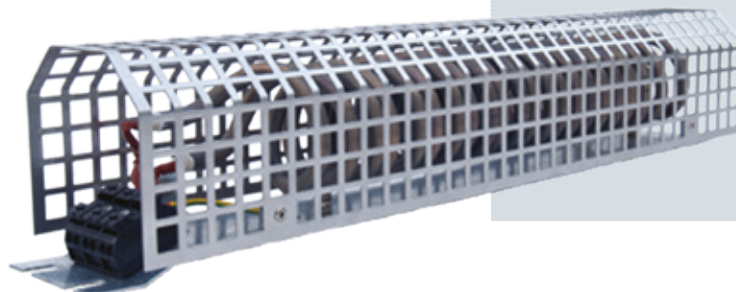

NIBE ELEMENT WIND SOLUTIONS provides conventional and PTC semi-conductor control panel heaters and fan-assisted heaters ranging from 5W to 1200W, as well as tropicalized and EX versions.



THERMOSTATS

The NIBE ELEMENT WIND SOLUTIONS temperature and humidity controls range from 0°C to 60°C and 35% to 100% RH.

Temperature sensors

Temperature sensors are used in various places in the wind turbine, among other things for measurements in:

- bearings
- hydraulic systems
- gear oil
- control cabinet temperatures

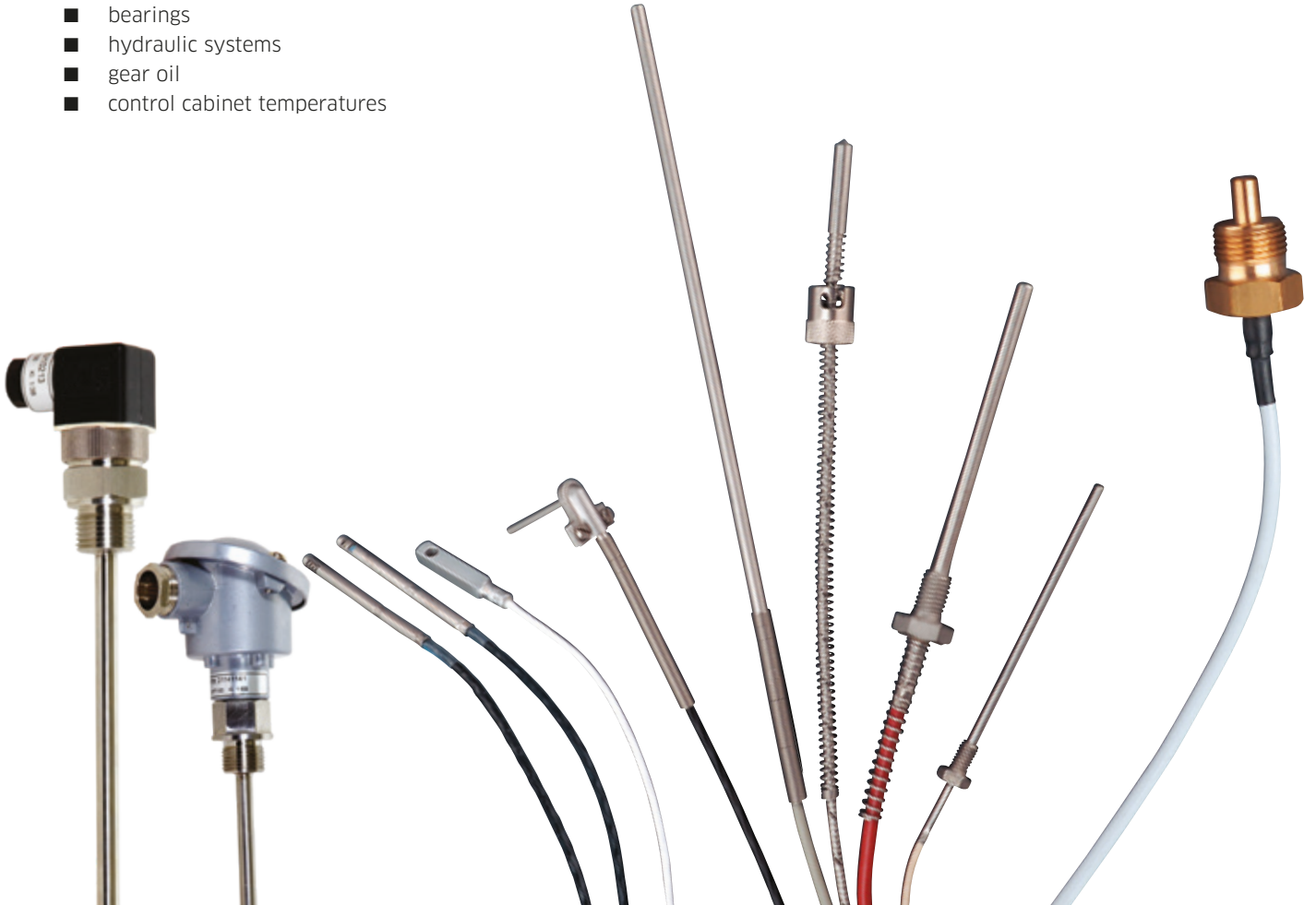

PT100 TEMPERATURE SENSORS

Pt100 temperature sensors for monitoring temperatures in control cabinets, nacelles and for external temperature monitoring.

Hydraulic and lubrication oil monitoring.
Used for e.g. gears and brakes.

Humidity sensors for monitoring humidity levels in nacelles and control cabinets.

Spring loaded Pt100 sensors for bearing temperature measurement.



Cartridge heaters

High watt cartridge heaters for building into tools, injection presses, nozzles, and moulds. The extremely high load in connection with the fine physical tolerances provide high heat transmission over a minimum area.

Special cartridge heaters with differentiated output, built-in thermal fuse, sensor or thermostat are available upon request.

Immersion heaters for small oiltanks.
Built-in thermostat.
Customized solutions.



Whenever NIBE ELEMENT WIND SOLUTIONS receives an inquiry from a customer, we always work very close with the engineers to calculate, design, and test what we expect will be the final solution.

Thus generating satisfied customers and well defined solutions which will last for many years.

NIBE ELEMENT WIND SOLUTIONS has the knowledge required for heating solutions, and our customers have derived their knowledge from the way the applications work.

Together we form the strongest team and find the best solution.

Silicone heaters

The NIBE ELEMENT WIND SOLUTIONS silicone heaters are used for any application with precise and intimate heating requirements. Our silicone heaters are lightweight and thin, generating low thermal mass and rapid heat up characteristics, responding quickly to temperature control.

Our silicone heaters are available with or without insulation and are all customized.



Battery box heater

Custom design to any application.

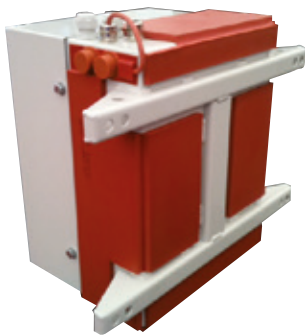

Silicone heating mat

Pre-bent for heating up pipelines.



Silicone heating mat

With thermostat, limiter, hooks, and springs.



Silicone heaters

- Designed to customer requirements
- Easy to install
- No maintenance
- Flexible and lightweight
- Etch foil and wire wound technology



NIBE ELEMENT WIND SOLUTIONS

RELIABILITY · ENERGY EFFICIENCY · SUSTAINABILITY

NIBE ELEMENT WIND SOLUTIONS was founded in 2009. The company is a division of Swedish NIBE Element, and coordinates sales to the wind sector globally for the five Danish companies of SAN Electro Heat a/s, Danotherm A/S, JEVI A/S, Lund & Sorensen A/S, and Eltwin Motron A/S. The company was established to offer our customers optimal service by uniting the coordination of the sales of all five companies in one office. Our main office is situated in Vejle, Denmark. However, due to our representation - sales as well as production - all over the World, we are in a position to service our customers everywhere.

NIBE ELEMENT WIND SOLUTIONS - Heating Equipment for Cold Climate - offers design, production, and supply of electric heating solutions for the wind turbine industry. Production in Europe, America, and Asia.

PRODUCT DEVELOPMENT



PERFORMANCE TESTING

- Temperature and measurement
- Interior testing
- Thermal imaging
- Cooling room -25°C
- Noise testing
- Humidity chamber
- Life cycle testing
- Wind tunnel tests
- Resistor power testing
- Long term corrosion tests
- Electrical tests up to 24kV AC
- External resources for other types of tests such as shock and vibration and intermittent pulses.

MASTERING THE DESIGN

- Pro/ Engineer 3d-CAD
- X-ray equipment
- PDM-link/ Product data management etc.
- FLO EFD
 - Thermal/ flow simulations PTC MECHANICA
 - Thermal and stress analysis

QUALITY

We strive to deliver the highest quality products combined with a flexible way of working. This permeates the whole process from sales, product development, manufacturing, customer service and logistics. NIBE ELEMENT WIND SOLUTIONS delivers products that meet all relevant standards and tests, certifying products according to customer specifications. We also have possibilities to carry out tests in modern labs, constantly improving our product performance and energy efficiency.



INNOVATIONS FOR THE FUTURE

A partnership with us gives you a dedicated team of designers, project engineers and technical experts in the fields of electric heating, measurement and control, ready to provide you with the optimal solutions for your needs.



NIBE ELEMENT
WIND SOLUTIONS

NIBE ELEMENT WIND SOLUTIONS
Maserativej 4
DK- 7100 Vejle
Denmark
Tel.: +45 6155 1411
osb@nibewind.com
www.nibewind.com