

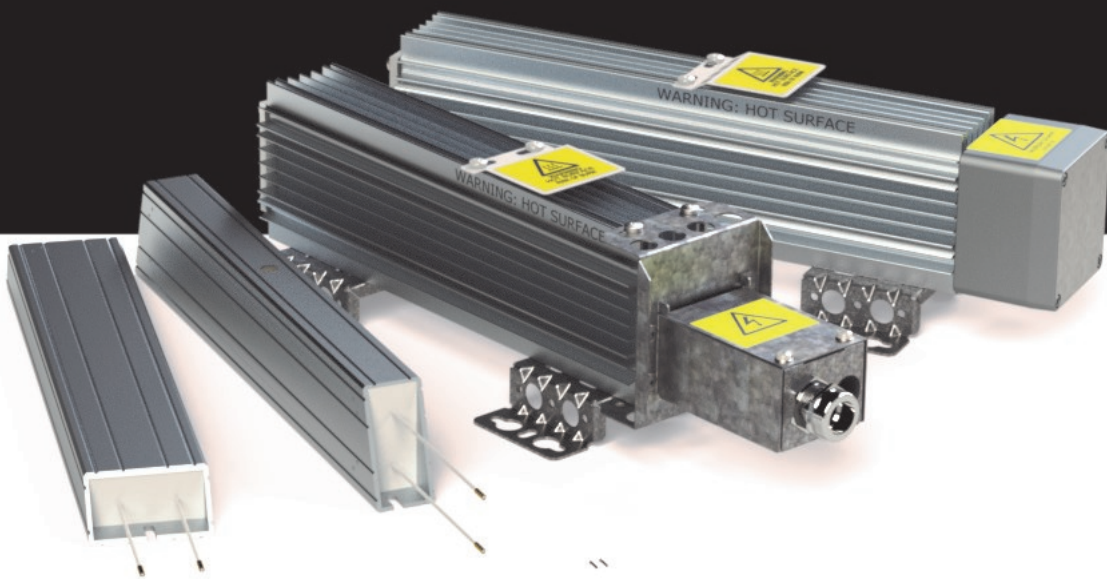

DANOTHERM™



CBH / CBV / CBR-V / CBR-H

- Brake resistors

- General-purpose applications; High pulse load applications
- Compact Construction; small dimensions
- Fully insulated; no external live parts
- High IP Classes
- Low thermal drift, 100ppm
- Fail Safe capabilities on request
- Low noise
- Thermal models for all types available on request
- Resistor components are UL approved

CBH/CBV CBR-V/CBR-H	Pn [W] @ 40°C According UL508	max temp. [°C]	R [Ω] min - max	Pulse load [kW] T. Amb. = 40°C each 120s *			
				duty 1 second [kW]	duty 5 second [kW]	duty 10 second [kW]	duty 40 second [kW]
CBH / CBV 165 C	110	265	0.5 - 1000	5	1.4	0.9	0.3
CBH / CBV 215 C	155	270	0.8 - 1500	9.8	2.5	1.6	0.5
CBH / CBV 265 C	200	270	1.5 - 2000	16.6	4.0	2.4	0.6
CBH / CBV 335 C	270	280	1.8 - 2000	26.6	6.2	3.4	0.9
CBH / CBV 405 C	330	285	2.0 - 2000	34.1	8.5	4.3	1
CBR-V / H 175 C	311	265	0.8 - 1500	10.5	2.7	1.8	0.9
CBR-V / H 225 C	400	270	1.5 - 2000	18.3	4.5	2.8	1.2
CBR-V / H 295 C	525	275	1.8 - 2000	29.7	7.1	4.2	1.8
CBR-V / H 365 C	650	280	2.0 - 2000	38.4	11.3	6.7	2.4
CBR-V / H 426 C	980	285	2.4 - 2000	39.1	12.9	7.9	2.9
CBR-V / H 526 C	1220	295	3.0 - 2000	49.1	16.1	9.9	3.6
CBR-V / H 626 C	1460	305	3.5 - 2000	60.6	19.7	12	4.4
CBR-V / H 726 C	1700	310	4.0 - 2000	73.1	23.4	14.3	5.2

Construction and salient properties

- UL approved
- Compact dimensions
- Nominal power range from 110W–1700W
- Energy levels from 9kJ-150kJ per case housing (5s duty,120s cycle), depending on ohmic value
- Aluminium case housing for high IP rating
- IP50-IP65
- Internal ceramic supported wirewound spirals for lower ohmic values
- Internal mica supported wirewound elements for higher ohmic values
- Nickel-Chrome 8020 alloy for low thermal drift
- Mica insulated for high dielectric strength
- Al₂O₃ or SiO₂ filled for high thermal capacity/high power overload capability
- Low surface temperature
- Low noise level
- High vibration withstand capability
- Thermal relief expansion mounting feet
- Optional thermal switch or PT100 element for thermal protection
- Cable (AWG 18–AWG10) or box connection up to 10mm²
- Customized to your needs and application (OEM versions available)



CBR-V 225 K

CBH / CBV / CBR cable connections IP54

with internal thermal switch

CBH/CBV CBR-V/CBR-H with Thermal switch	Pn [W] @ 40°C According UL508	max temp. [°C]	R [Ω] min - max	Pulse load [kW] T. Amb. = 40°C each 120s*			
				duty 1 second [kW]	duty 5 second [kW]	duty 10 second [kW]	duty 40 second [kW]
CBH / CBV 190 xT	85	210	0.5 - 1000	5	1.4	0.9	0.3
CBH / CBV 240 xT	120	215	0.8 - 1500	9.8	2.5	1.5	0.4
CBH / CBV 290 xT	150	220	1.5 - 2000	16.6	3.8	1.9	0.5
CBH / CBV 360 xT	200	225	1.8 - 2000	25.6	5.2	2.6	0.7
CBH / CBV 430 xT	250	230	2.0 - 2000	32.5	6.5	3.2	0.8
CBR-V / H 160 xT	280	210	0.5 - 1000	5.4	1.5	1	0.5
CBR-V / H 210 xT	360	210	0.8 - 1500	10.6	2.8	1.8	0.9
CBR-V / H 260 xT	450	225	1.5 - 2000	18.4	4.6	2.8	1.3
CBR-V / H 330 xT	570	230	1.8 - 2000	30	7.1	4.2	1.7
CBR-V / H 400 xT	680	230	2.0 - 2000	38.8	11.4	6.8	2.1
CBR-V / H 460 xT	790	240	2.4 - 2000	39.4	12.9	8	2.4
CBR-V / H 560 xT	960	250	3.0 - 2000	49.4	16.2	10	3.1
CBR-V / H 660 xT	1130	260	3.5 - 2000	60.6	19.7	12.1	3.8
CBR-V / H 760 xT	1290	260	4.0 - 2000	73.8	23.3	14.2	4.3

CBR K-box connection IP00

CBH/CBV CBR-V/CBR-H	Pn [W] @ 40°C	max temp. [°C]	R [Ω] min - max	Pulse load [kW] T. Amb. = 40°C each 120s*			
				duty 1 second [kW]	duty 5 second [kW]	duty 10 second [kW]	duty 40 second [kW]
CBR-V 175 K	235	210	0.8 - 1500	10.5	2.7	1.8	0.8
CBR-V 225 K	305	215	1.5 - 2000	18.3	4.5	2.8	1.1
CBR-V 295 K	400	220	1.8 - 2000	29.7	7.1	4.2	1.5
CBR-V 365 K	495	225	2.0 - 2000	38.4	11.3	6.7	1.9
CBR-V 426 K	750	230	2.4 - 40	39.1	12.9	7.9	2.3
CBR-V 526 K	930	235	3.0 45	49.1	16.1	9.9	2.9
CBR-V 626 K	1100	240	3.5 - 50	60.6	19.7	12	3.6
CBR-V 726 K	1300	250	4.0 - 55	73.1	23.4	14.3	4.3

* Pulse ratings for short pulses depend on the ohm value. Resistors with lower resistance value have more wire than resistors with higher resistance values. The ratings in this table refer to resistors of about 40R.

General specifications

Temperature Coefficient:		100 ppm/K
Dielectric strength		3500 VAC @ 1 minute
Isolation Resistance:		> 20M Ω / case housing
Overload:@ 1 sec pulse / hour		40 - 120 x (depending on resistor)
Overload:@ 5 sec pulse / hour		10 - 27 x (depending on resistor)
Environmental:		- 40 °C / +70 °C
De-rating cable version		Linear: 40°C = Pn to 70°C = 0.85 * Pn
De-rating TW 200°C version		Linear: 40°C = Pn to 70°C = 0.65 * Pn
De-rating vertical mounting		no de-rating
De-rating horizontal mounting		0.8 * Pn
De-rating at high altitudes	1000 m	no de-rating
	1500 m	0.94 * Pn
	3000 m	0.82 * Pn
Mounting instructions		It is recommended to keep a distance of 200mm to the nearest object to prevent heating of a neighboring component.
		If two or more brake resistors are mounted next to each other the distance between these should be 400mm. If this is less then the nominal power needs to be de-rated.
Cooling		The nominal power of the resistors refers to cooling conditions with Free Natural Air Cooling.
Vibration		Acc. To EN 60068-2-6 frequency range 1 - 100Hz Acceleration / Amplitude
	1 - 13 Hz	± 1mm
	13 - 100 Hz	@ ± 0.7G
Corrosive resistance		Acc. IEC 60721-3-3/3K3 (C2 medium) 200 hours cyclic salt mist IEC 60068-2-52
Connection recommendations		To minimize EMC interference screened cables are recommended. in particular with any PWM brake pattern.
Resistance tolerance		± 10% (optional 5%)
Working voltage	Standard	UL: 600VAC. IEC: 690VAC / 1100VDC
	On request	UL: 1000VAC. IEC: 1000VAC / 1400VDC
Time constant for heating up resistor		1000s
Thermal switch (optional)	Thermal switch	130 / 160 / 180 / 200 °C. 2A. 250 VAC NC
Minimum voltage		2V
Minimum current		10mA
Rated current / voltage		2.5A @ 250 VAC cos ϕ =1
Dielectric voltage		2000VAC (3500VAC between TS and R)
Temperature requirements on cables	IP 21	80°C
	IP 65	90°C

Connection boxes, only CBR types (optional)

connection boxes	IP rating	cable gland	clamping	braid (min.)	connection	TS gland	clamping	connection
			[mm]	[mm]	[mm ²]		[mm]	[mm]
B-box	IP65	M25	9-16.6	7.5	0.75-10	M12	3-7	0.5-4
D-box	IP21	M25	9-16.6	7.5	0.75-10	M12	3-7	0.5-4
K-box	IP00	-	-	-	0.75-10	-	-	0.5-4*

*TS with K-box optional

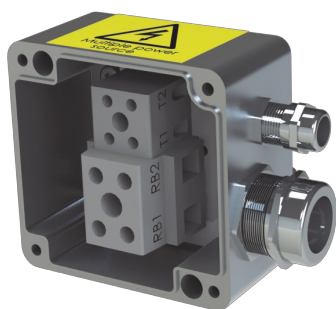

B-box

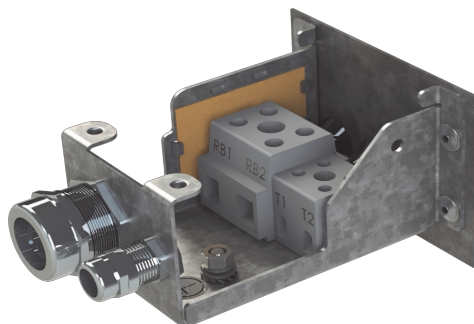

D-box



K-box

CBH / CBV Cable cable connection IP54

Type	L ± 2	L1 ± 2	Weight
	±2mm	±2mm	kg
CBH / CBV 165 C 800	165	146	0.39
CBH / CBV 215 C 800	215	196	0.63
CBH / CBV 265 C 800	265	246	0.88
CBH / CBV 335 C 800	335	316	1.2
CBH / CBV 405 C 800	405	386	1.5

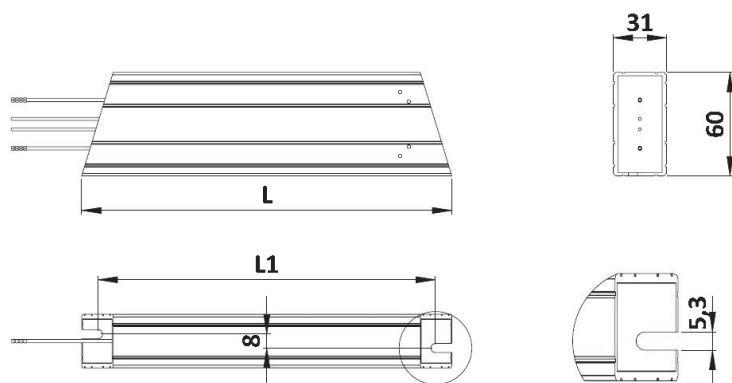

CBH/CBV cable connections IP54

with internal thermal switch

Type	L	L1	Weight
	±2mm	±2mm	kg
CBH/CBV 190 CT 800	190	171	0.5
CBH/CBV 240 CT 800	240	221	0.71
CBH/CBV 290 CT 800	290	271	0.97
CBH/CBV 360 CT 800	360	341	1.3
CBH/CBV 430 CT 800	430	411	1.6

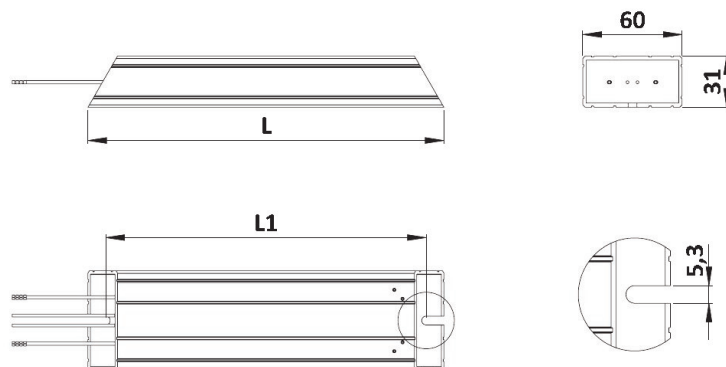

CBR cable connections IP54

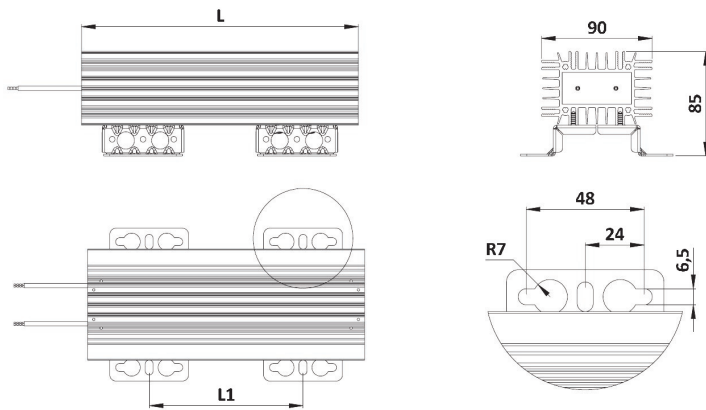

Type	L ± 2 ±2mm	L1 ± 2 ±2mm	Weight kg
CBR-V/CBR-H 175 C 001	175	75	1.5
CBR-V/CBR-H 225 C 001	225	125	1.8
CBR-V/CBR-H 295 C 001	295	195	2.3
CBR-V/CBR-H 365 C 001	365	265	2.8
CBR-V/CBR-H 426 C 001	426	326	3.2
CBR-V/CBR-H 526 C 001	526	426	3.8
CBR-V/CBR-H 626 C 001	626	526	4.5
CBR-V/CBR-H 726 C 001	726	626	5.2

CBR-V cable connections IP54 - with internal thermal switch

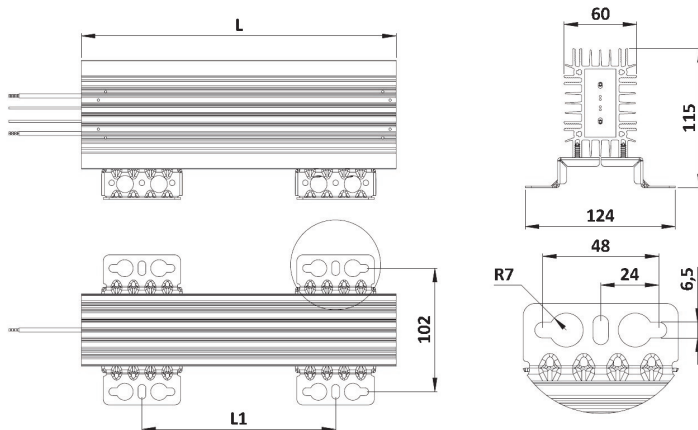

-H / -V W(T)	L ±2mm	L1 ±2mm	Weight kg
CBR-H/CBR-V 160 CT 081	160	70	1.5
CBR-H/CBR-V 210 CT 081	210	110	1.8
CBR-H/CBR-V 260 CT 081	260	160	2.1
CBR-H/CBR-V 330 CT 081	330	230	2.6
CBR-H/CBR-V 400 CT 081	400	300	3.1
CBR-H/CBR-V 460 CT 081	460	360	3.5
CBR-H/CBR-V 560 CT 081	560	460	4.1
CBR-H/CBR-V 660 CT 081	660	560	4.8
CBR-H/CBR-V 760 CT 081	760	660	5.5

CBR-V B-box connection IP54 - with internal thermal switch

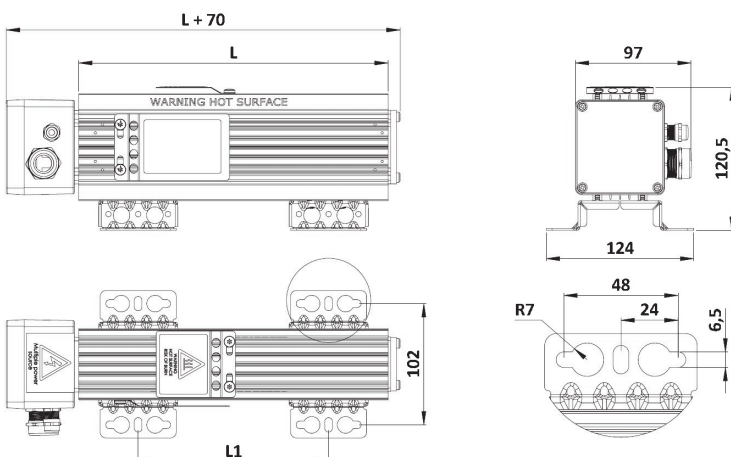

Type	L ±2mm	L1 ±2mm	Weight kg
CBR-V 160 B T 281	160	70	1.3
CBR-V 210 B T 281	210	110	1.8
CBR-V 260 B T 281	260	160	2.4
CBR-V 330 B T 281	330	230	3.0
CBR-V 400 B T 281	400	300	3.5
CBR-V 460 B T 281	460	360	3.9
CBR-V 560 B T 281	560	460	4.6
CBR-V 660 B T 281	660	560	5.4
CBR-V 760 B T 281	760	660	6.1

CBR connection cable IP65 'W' type IP65 with or without internal thermal switch

-H / -V W(T)	L	L1	Weight
	±2mm	±2mm	kg
CBR-H/CBR-V 160 XX 081	160	70	1.5
CBR-H/CBR-V 210 XX 081	210	110	1.8
CBR-H/CBR-V 260 XX 081	260	160	2.1
CBR-H/CBR-V 330 XX 081	330	230	2.6
CBR-H/CBR-V 400 XX 081	400	300	3.1
CBR-H/CBR-V 460 XX 081	460	360	3.5
CBR-H/CBR-V 560 XX 081	560	460	4.1
CBR-H/CBR-V 660 XX 081	660	560	4.8
CBR-H/CBR-V 760 XX 081	760	660	5.5

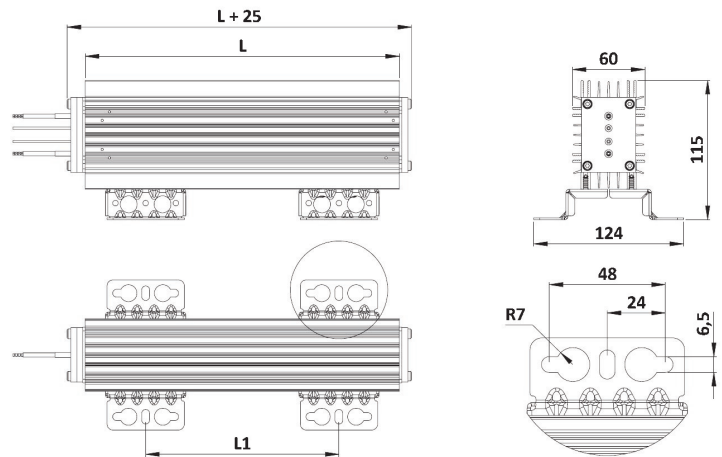

CBR D-box connection IP20/IP21 - with internal thermal switch

Type	L	L1	Weight
	±2mm	±2mm	kg
CBR-V 160 D T 281	160	70	1.3
CBR-V 210 D T 281	210	110	1.8
CBR-V 260 D T 281	260	160	2.4
CBR-V 330 D T 281	330	230	3.0
CBR-V 400 D T 281	400	300	3.5
CBR-V 460 D T 281	460	360	3.9
CBR-V 560 D T 281	560	460	4.6
CBR-V 660 D T 281	660	560	5.4
CBR-V 760 D T 281	760	660	6.1

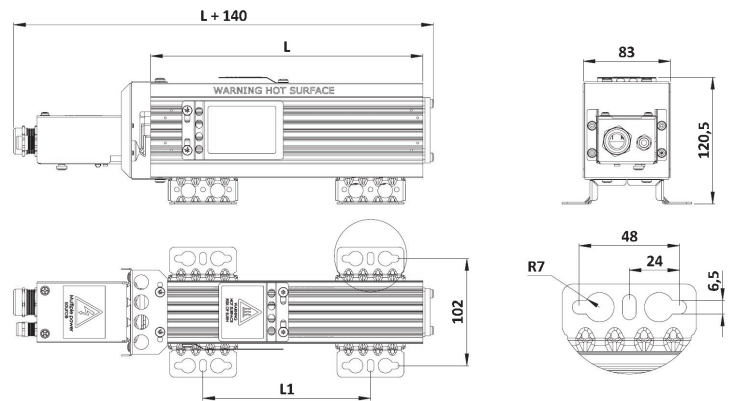

CBR K-box connection IP00 - without internal thermal switch

Type	L	L1	Weight
	±2mm	±2mm	kg
CBR-V 175 K 201	175	75	1.3
CBR-V 225 K 201	225	125	1.8
CBR-V 295 K 201	295	195	2.4
CBR-V 365 K 201	365	265	3.0
CBR-V 426 K 201	426	326	3.5
CBR-V 526 K 201	526	426	3.9
CBR-V 626 K 201	626	526	4.6
CBR-V 726 K 201	726	626	5.4

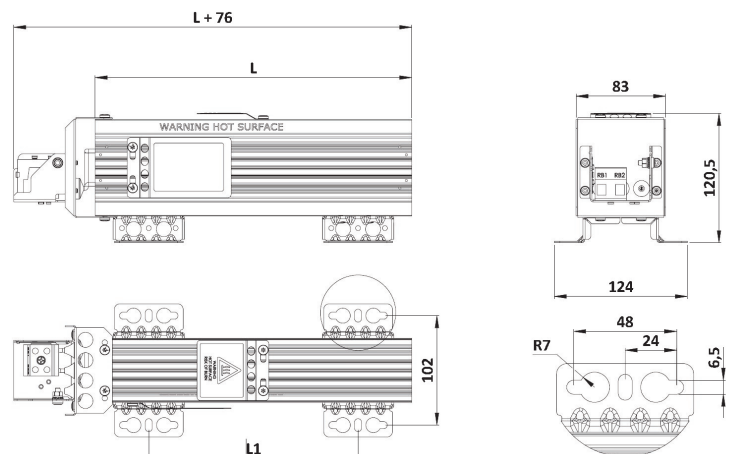

Overview of the ALPHA resistor family (IP00-IP65)

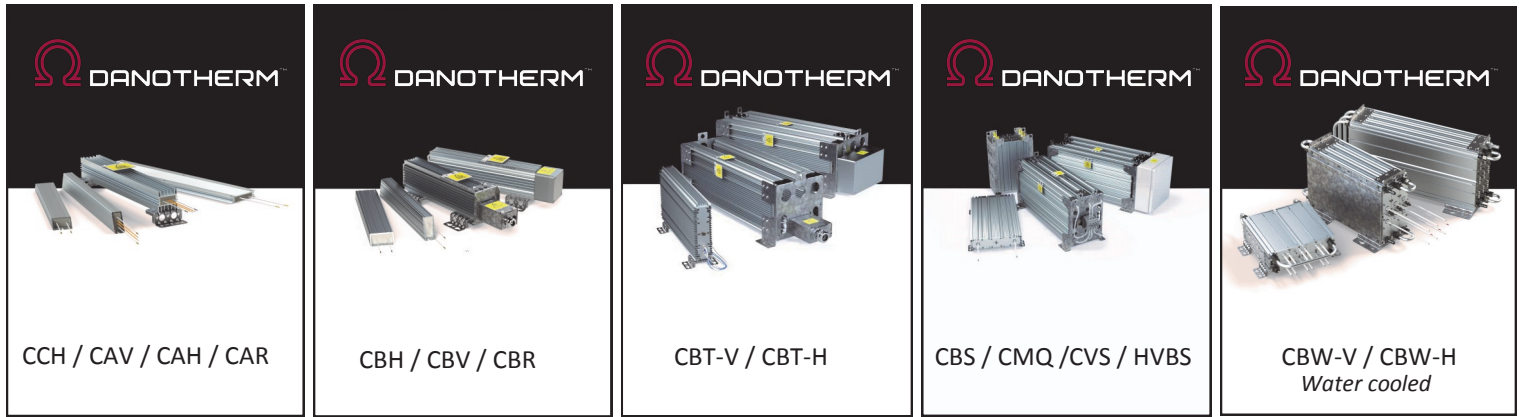

Power: 60-410W	Power: 85W-1.7kW	Power: 410W-12kW	Power: 445W-15kW	Power: 860W-25kW
	9-150kJ @5s	25-550kJ @5s	80kJ-2.5MJ @5s	6.4kJ-1.1MJ @5s
- Applications				
Charge / Discharge	High Pulse load	High Pulse load	High Pulse load	Short recovery time
Brake	Brake	Brake	Brake	Brake
Filter	Filter	Filter	Medium voltage	Filter
	Charge / Discharge	Charge / Discharge	Charge / Discharge	High Pulse load

Other resistor types from Danotherm (IP00-IP66)



Multi purpose	Outdoor & Marine	Filter	Medium & High voltage	Filter & load
Power: 100W-5kW	Power: 1-500kW	Power: 4-200kW	Power: 500W->	Power: 5kW-1MW
Ceramic wirewound	Steel tube	Wirewound	Steel grid	Steel tube

CBR-V 400 CH(T) 2 8 1 22R

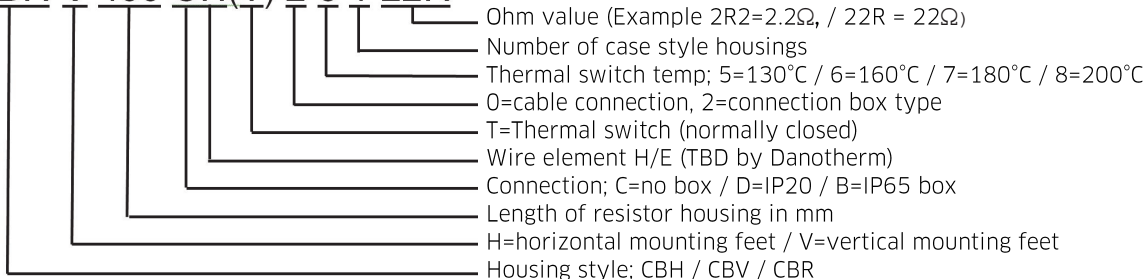

Danotherm Electric A/S
 Naesbyvej 20
 DK-2610 Roedovre
 Denmark
 CVR 1012 6061

DAN EN 16.5015.R3
 19022017

