

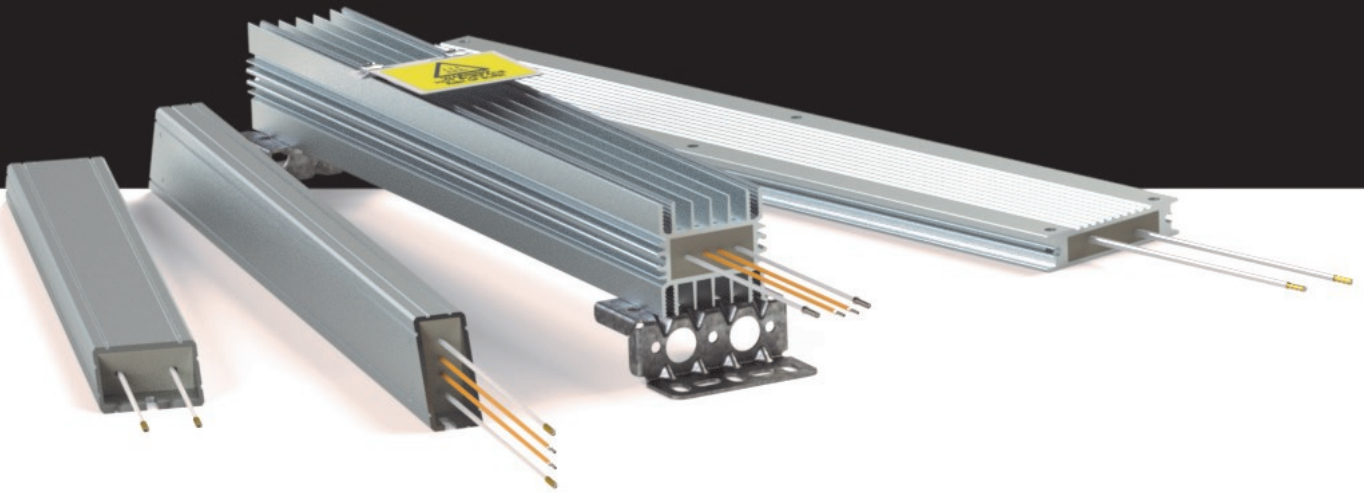

DANOTHERM™



CCH / CAH / CAV / CAR

- Brake resistors

- General-purpose applications; High pulse load applications
- Compact Construction; small dimensions
- Fully insulated; no external live parts
- High IP Classes
- Low thermal drift, 100ppm
- Fail Safe capabilities on request
- Low noise
- Thermal models for all types available on request
- Resistor components are UL approved

CCH with and without thermal switch

P _n W @ 40°C According UL508								
CAH/CAV CAR	P _n W @ 40°C According UL508	max temp. °C	R _Ω min - max	Pulse load W T. amb. = 40°C each 120s				
				duty 1 second W	duty 5 second W	duty 10 second W	duty 20 second W	duty 40 second W
CCH 110	100	260	2 - 1000	2500	1150	800	540	295
CCH 166	160	265	4 - 1200	5700	2380	1600	930	470
CCH 216	200	275	6 - 1500	10500	3760	2350	1180	590
CCH 270	260	280	9 - 1700	14200	5050	3080	1540	770
CCH 320	300	285	10 - 2000	18600	6320	3550	1780	890
CCH 420	390	295	13 - 2000	24700	8390	4590	2290	1160
CCH 520	480	305	16 - 2000	30300	9710	5760	2880	1440
CCH 620	570	315	20 - 2000	38100	11900	6890	3440	1720
CCH with internal thermal switch								
CCH 145 CT	80	210	2 - 1000	2540	1210	850	580	345
CCH 201 CT	120	215	4 - 1200	5780	2480	1690	920	460
CCH 251 CT	160	220	6 - 1500	10600	3940	2280	1140	570
CCH 305 CT	200	225	9 - 1700	14500	5220	2820	1410	700
CCH 355 CT	230	230	10 - 2000	19100	6550	3280	1640	820
CCH 455 CT	300	235	13 - 2000	25300	8310	4150	2080	1040
CCH 555 CT	370	245	16 - 2000	30900	10000	5170	2590	1290
CCH 655 CT	440	250	20 - 2000	38800	11800	5900	2950	1500

Construction and salient properties

- UL approved
- Compact dimensions
- Nominal power range from 80W–440W
- Energy levels from 6kJ-60J (5s duty,120s cycle), depending on ohmic value
- Aluminium case housing for high IP rating
- IP50-IP65
- Nickel-Chrome 8020 alloy for low thermal drift
- Mica insulated for high dielectric strength
- MgO or SiO₂ filled for high thermal capacity/ high power overload capability
- Low surface temperature
- Low noise level
- High vibration withstand capability
- Thermal relief expansion mounting feet (CAR type)
- Optional thermal switch or PT100 element for thermal protection
- Cable (AWG 18–AWG10) or box connection up to 10mm²
- Customized to your needs and application (OEM versions available)

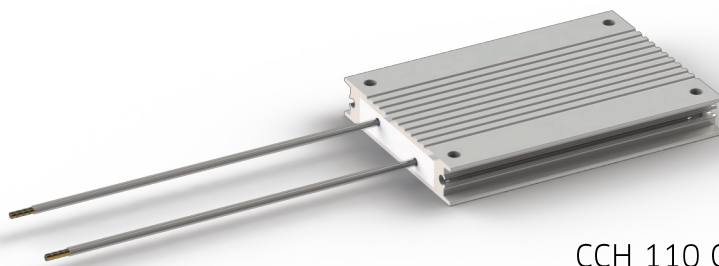

CCH 110 C

CAH/CAV/CAR cable connection

P _n W @ 40°C According UL508								
CAH/CAV CAR	P _n W @ 40°C According UL508	max temp. °C	R min - max Ω	Pulse load kW T. amb. = 40°C each 120s				
				duty 1 second W	duty 5 second W	duty 10 second W	duty 20 second W	duty 40 second W
CAH / CAV 120 C	70	260	0.15 - 300	1070	410	320	240	170
CAH / CAV 150 C	90	260	0.3 - 600	2420	820	600	435	255
CAH / CAV 165 C	100	265	0.3 - 800	3630	1120	780	540	285
CAH / CAV 210 C	125	270	0.6 - 1200	7030	1800	1120	750	375
CAH / CAV 240 C	145	275	0.7 - 1500	9530	2350	1440	850	435
CAH / CAV 300 C	185	290	1 - 1200	12800	3150	1920	1100	550
CAH / CAV 360 C	220	305	1.2 - 2500	16700	4080	2460	1320	660
CAR 85 C	115	260	0.1 - 300	1090	420	330	250	180
CAR 115 C	150	265	0.25 - 600	2480	860	640	470	330
CAR 130 C	170	265	0.3 - 800	3750	1170	830	600	405
CAR 175 C	225	275	0.5 - 1200	7420	1910	1230	830	570
CAR 205 C	260	285	0.7 - 1400	10200	2540	1590	1050	700
CAR 265 C	335	300	1.0 - 2000	13800	3460	2140	1420	940
CAR 325 C	410	320	1.2 - 2500	18100	4460	2750	1810	1170

Cable and connection box

with and without thermal switch

P _n W @ 40°C According UL508								
CAH/CAV CAR	P _n W @ 40°C According UL508	max temp. °C	R min - max Ω	Pulse load kW T. amb. = 40°C each 120s				
				duty 1s second W	duty 5s second W	duty 10s second W	duty 20s second W	duty 40s second W
CAH / CAV 145 CT	60	210	0.15 - 300	1070	415	325	245	170
CAH / CAV 175 CT	75	210	0.3 - 600	2420	830	610	430	215
CAH / CAV 190 CT	80	215	0.3 - 800	3630	1120	780	460	235
CAH / CAV 235 CT	100	220	0.6 - 1200	7030	1810	1130	580	290
CAH / CAV 265 CT	110	220	0.7 - 1500	9530	2350	1340	670	335
CAH / CAV 325 CT	140	230	1 - 1200	12800	3180	1660	830	415
CAH / CAV 385 CT	165	235	1.2 - 2500	16700	3980	1990	1000	495
CAR 110 CT/K/DT	105	210	0.1 - 300	1090	425	335	260	185
CAR 140 CT/K/DT	135	210	0.25 - 600	2500	870	650	485	335
CAR 155 CT/K/DT	150	215	0.3 - 800	3750	1190	840	610	420
CAR 200 CT/K/DT	190	220	0.5 - 1200	7420	1940	1240	850	560
CAR 230 CT/K/DT	210	225	0.7 - 1400	10200	2560	1600	1060	630
CAR 290 CT/K/DT	265	235	1.0 - 2000	13800	3490	2150	1430	780
CAR 350 CT/K/DT	310	250	1.2 - 2500	18100	4500	2760	1810	930

Pulse ratings for short pulses depend on the ohm value. Resistors with lower resistance value have more wire than resistors with higher resistance values. The ratings in this table refer to resistors of about 40R.

General specifications

Temperature Coefficient:		100 ppm/K
Dielectric strength		3500 VAC @ 1 minute
Isolation Resistance:		> 20M Ω / case housing
Overload:@ 1 sec pulse / hour		10 - 100 x (depending on resistor)
Overload:@ 5 sec pulse / hour		4 - 25 x (depending on resistor)
Environmental:		- 40 °C / +70 °C
De-rating cable version		Linear: 40°C = Pn to 70°C = 0.85 * Pn
De-rating TW 200°C version		Linear: 40°C = Pn to 70°C = 0.65 * Pn
De-rating vertical mounting		no de-rating
De-rating horizontal mounting		0.8 * Pn
De-rating at high altitudes	1000 m	no de-rating
	1500 m	0.94 * Pn
	3000 m	0.82 * Pn
Mounting instructions		It is recommended to keep a distance of 200mm to the nearest object to prevent heating of a neighboring component.
		If two or more brake resistors are mounted next to each other the distance between these should be 400mm. If this is less then the nominal power needs to be de-rated.
Cooling		The nominal power of the resistors refers to cooling conditions with Free Natural Air Cooling.
Vibration		Acc. To EN 60068-2-6 frequency range 1 - 100Hz Acceleration / Amplitude
	1 - 13 Hz	\pm 1mm
	13 - 100 Hz	@ \pm 0.7G
Corrosive resistance		Acc. IEC 60721-3-3/3K3 (C2 medium) 200 hours cyclic salt mist IEC 60068-2-52
Connection recommendations		To minimize EMC interference screened cables are recommended. in particular with any PWM brake pattern.
Resistance tolerance		\pm 10% (optional 5%)
Working voltage		UL: 600VAC. IEC: 690VAC / 850VDC
Time constant for heating up resistor		1000s
Thermal switch (optional)	Thermal switch	130 / 160 / 180 / 200 °C. 2A. 250 VAC NC
Minimum voltage		2V
Minimum current		10mA
Rated current / voltage		2.5A @ 250 VAC cos ϕ =1 2.5A @ 24 VDC
Dielectric voltage		2000VAC (3500VAC between TS and R)
Temperature requirements on cables	IP 21	80°C
	IP 65	90°C

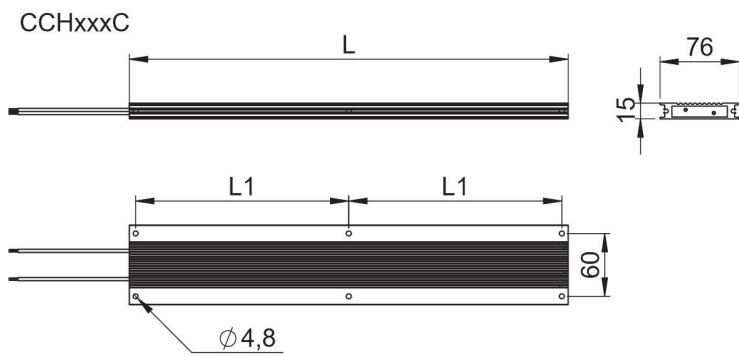

Type	L ± 2 mm	L1 ± 2 mm	Weight g
CCH 110	110	98	220
CCH 166	166	154	350
CCH 216	216	204	480
CCH 270	270	258	620
CCH 320	320	2x154	790
CCH 420	420	2x204	1050
CCH 520	520	2x241.5	1300
CCH 620	620	2x291.5	1550

CCH Cable version with thermal switch, IP54

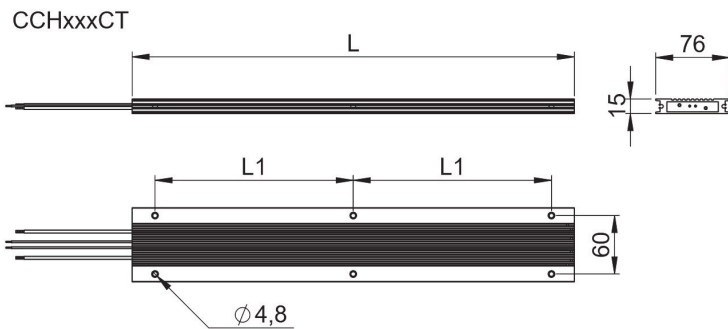

Type	L ± 2 mm	L1 ± 2 mm	Weight g
CCH 145 CT	145	98	270
CCH 201 CT	201	154	410
CCH 251 CT	251	204	540
CCH 305 CT	305	258	620
CCH 355 CT	355	2x154	850
CCH 455 CT	455	2x204	1110
CCH 555 CT	555	2x241.5	1360
CCH 655 CT	655	2x291.5	1610

CCH Cable version IP65, thermal switch IP65

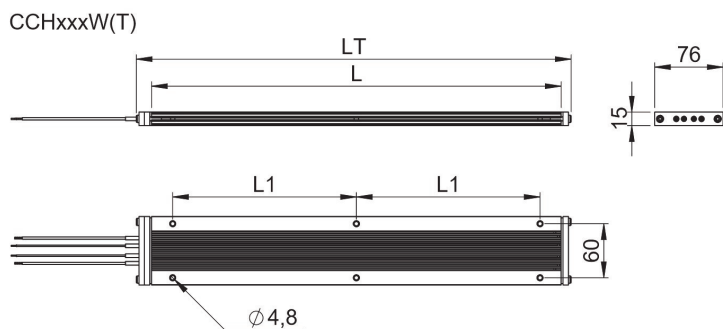

Type	L ± 2 mm	L1 ± 2 mm	Weight g
CCH 145 W(T)	145	98	270
CCH 201 W(T)	201	154	410
CCH 251 W(T)	251	204	540
CCH 305 W(T)	305	258	620
CCH 355 W(T)	355	2x154	850
CCH 455 W(T)	455	2x204	1110
CCH 555 W(T)	555	2x241.5	1360
CCH 655 W(T)	655	2x291.5	1610

Cable version IP54, thermal switch optional

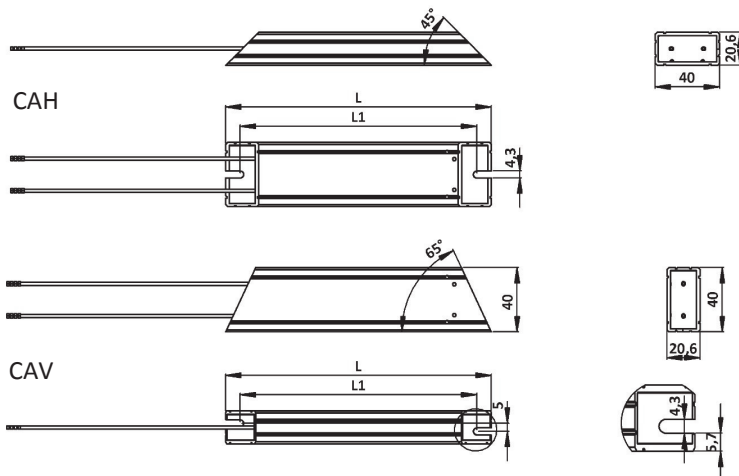

Type	L ± 2 mm	L1 ± 2 mm	Weight g
CAH / CAV 120 C	120	102	160
CAH / CAV 150 C	150	132	185
CAH / CAV 165 C	165	147	220
CAH / CAV 210 C	210	192	315
CAH / CAV 240 C	240	222	370
CAH / CAV 300 C	300	282	460
CAH / CAV 360 C	360	342	550
with thermal switch (T)			
CAH / CAV 145 CT	145	127	130
CAH / CAV 175 CT	175	157	160
CAH / CAV 190 CT	190	172	190
CAH / CAV 235 CT	235	217	280
CAH / CAV 265 CT	265	247	335
CAH / CAV 325 CT	325	307	425
CAH / CAV 385 CT	385	367	515

CAR cable type

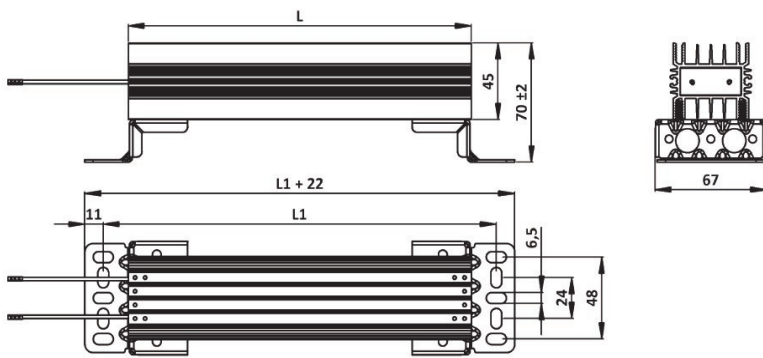

Type	L ±2mm	L1 ±2mm	Weight g
CAR 85 C	85	115	200
CAR 115 C	115	145	280
CAR 130 C	130	160	300
CAR 175 C	175	205	380
CAR 205 C	205	235	530
CAR 265 C	265	295	600
CAR 325 C	325	355	740
with thermal switch (T)			
CAR 110 CT	110	140	155
CAR 140 CT	140	170	230
CAR 155 CT	155	185	250
CAR 200 CT	200	230	335
CAR 230 CT	230	260	470
CAR 290 CT	290	320	550
CAR 350 CT	350	380	685

CAR K-Box

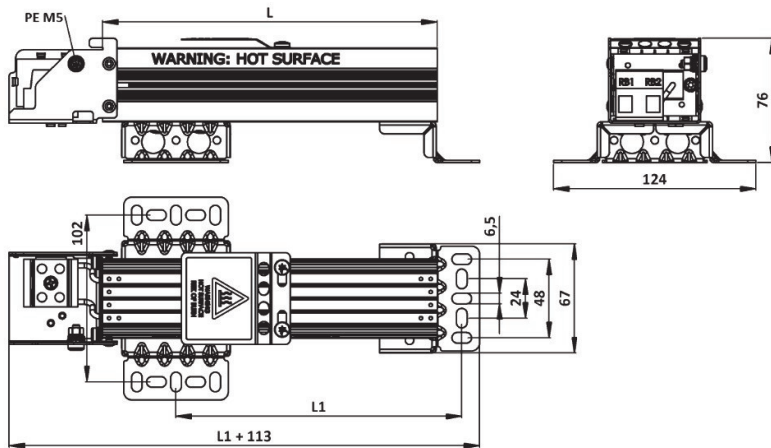

CAR Box type connection

Type	L ± 2 mm	L1 ± 2 mm	Weight g
with connection box			
CAR 115 K/-D	115	85	450/650
CAR 130 K/-D	130	100	470/700
CAR 175 K/-D	175	145	550/750
CAR 205 K/-D	205	175	700/900
CAR 265 K/-D	265	235	800/950
CAR 325 K/-D	325	195	900/1100

CAR DT-Box

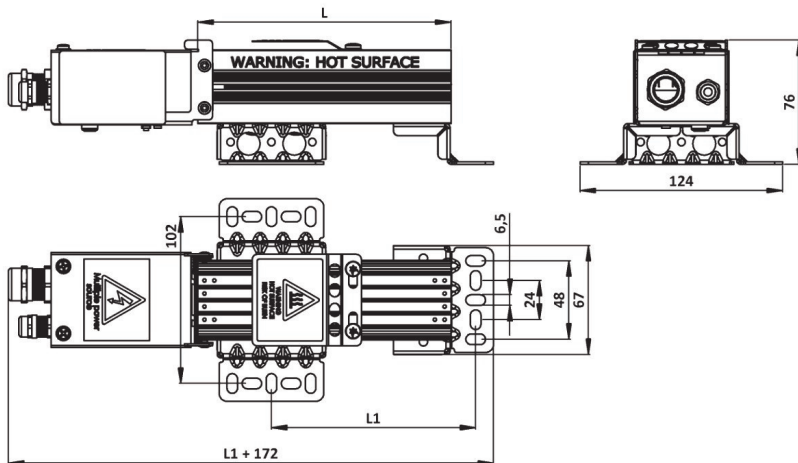

CAR Box type connection and thermal switch

Type	L ± 2 mm	L1 ± 2 mm	Weight g
with connection box			
CAR 140 K / -DT	140	110	510/720
CAR 155 K / -DT	155	125	540/760
CAR 200 K / -DT	200	170	610/810
CAR 230 K / -DT	230	200	760/960
CAR 290 K / -DT	290	260	860/1010
CAR 350 K / -DT	350	320	970/1160

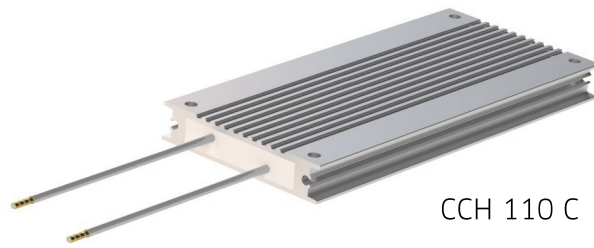

CCH 110 C

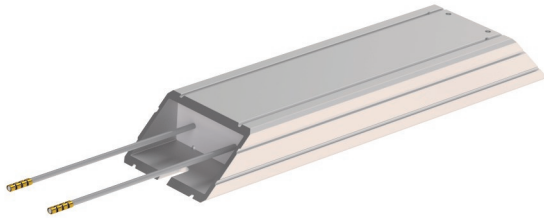

CAH 120 C

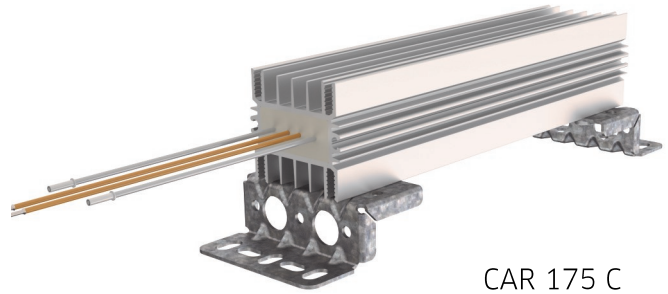

CAR 175 C

Connection boxes, only CAR types

connection boxes	IP rating	cable gland	clamping mm	braid (min.) mm	connection mm ²	TS gland mm	clamping mm	connection mm ²
D-box	IP21	M25	9-16.6	7.5	0.75-10	M12	3-7	0.5-4
K-box	IP00	-	-	-	0.75-10	-	-	0.5-4*

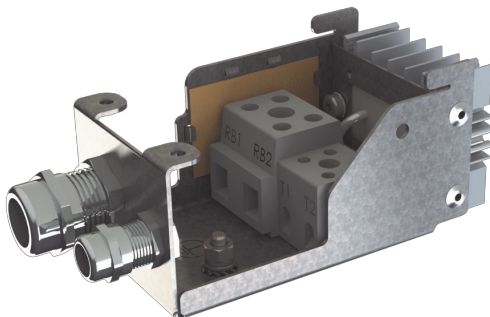

D-box

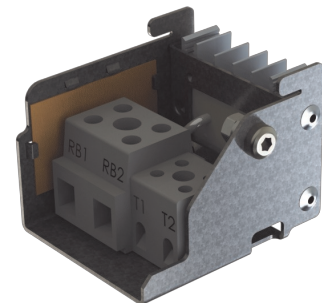

KT-box

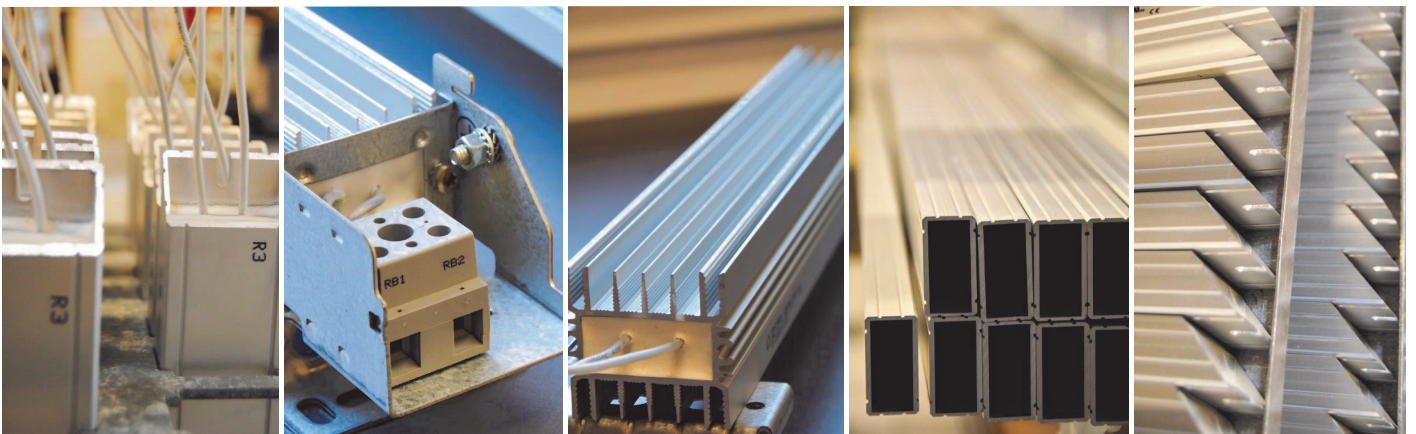

Overview of the ALPHA resistor family (IP00-IP65)

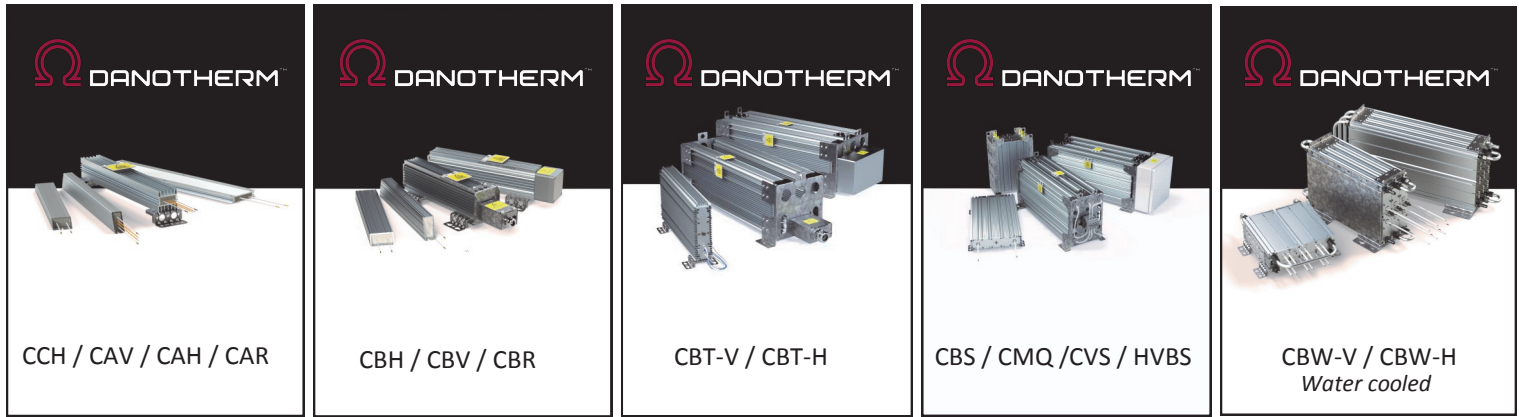

Power: 60-410W	Power: 85W-1.7kW	Power: 410W-12kW	Power: 445W-15kW	Power: 860W-25kW
	9-150kJ @5s	25-550kJ @5s	80kJ-2.5MJ @5s	6.4kJ-1.1MJ @5s
- Applications				
Charge / Discharge	High Pulse load	High Pulse load	High Pulse load	Short recovery time
Brake	Brake	Brake	Brake	Brake
Filter	Filter	Filter	Medium voltage	Filter
	Charge / Discharge	Charge / Discharge	Charge / Discharge	High Pulse load

Other resistor types from Danotherm (IP00-IP66)



Multi purpose	Outdoor & Marine	Filter	Medium & High voltage	Filter & load
Power: 100W-5kW	Power: 1-500kW	Power: 4-200kW	Power: 500W->	Power: 5kW-1MW
Ceramic wirewound	Steel tube	Wirewound	Steel grid	Steel tube

CAR 400 C(H)(T) 2 8 1 22R

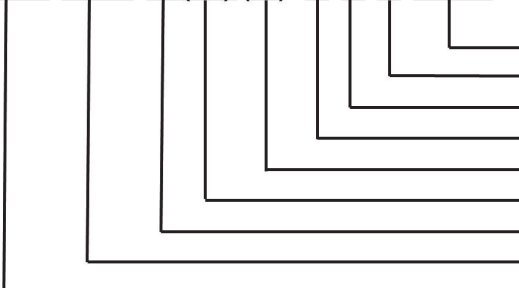

Last digits > 400: Customer specific version, otherwise:

Ohm value (Example 2R2=2.2Ω, / 22R = 22Ω)

Number of case style housings

Thermal switch; 5=130°C / 6=160°C / 7=180°C / 8=200°C

0=cable connection, 2=connection box type

T=Thermal switch (normally closed)

Wire element (H, TBD by Danotherm)

Danotherm Electric A/S
 Naesbyvej 20
 DK-2610 Roedovre
 Denmark
 CVR 1012 6061

DAN EN 16.5026.R1
 17MAY2017

