



DANOTHERM™



The high power Resistor Collection

- Resistors for filter and brake applications
- Natural air / forced air cooled and liquid cooled
- Suited for harsh environmental conditions
- Stainless steel tube elements
- High IP ratings



Welcome to the world of power resistors





WHDN



TRV



G12RT



WHBS



WHHB



WHB



HVB

Type	Power [kW]	Working Voltage [VAC]	Protection degree	Cooling	Page
WHDN	40 - 1450	1000	IP65/IP66	Liquid	4
WHHB	5 - 25	6,000	IP00/IP65	Liquid	9
WHBS	6 - 100	1000	IP65/IP66	Liquid	11
WHB	6 - 23	1000	IP65	Liquid	13
HVB	0.6 - 1.2	4,500	IP65	Air	14
TRV	50 - 275	1000	IP65/IP66	Forced air	16
GxxRT	3 - 32	1000	IP65/IP66	Air	18

Preface

Resistenze Elettriche Busto Arsizio (REBA) was founded in 1970 in Busto Arsizio, which is located nearby Milan, Italy. REBA is a division of Backer Fer s.r.l which is owned by NIBE Industrier AB, a stock exchange listed company from Sweden. REBA, is part of NIBE Element, Danotherm Resistor division.

The production of resistors, made with steel tube elements, filled with magnesium oxide, is a well established production process and the basis for many of Danotherm's resistors with natural, forced-air and water-cooling. Next to this technique REBA also engineer and produce resistors in other techniques.

The engineering team consists of highly qualified and experienced engineers, who lay the basis for all resistors. Most resistors are customized to the specific customer's need and environmental conditions. The engineering team uses 3D CAD software and the production is carried out by a highly specialized workforce.

Each customized resistor starts with the customer's specifications and the electrical load conditions. With resistor thermal models and simulation software, the resistor is dimensioned to the appropriate size. In this way the resistor is not over or under-dimensioned, giving the customer confidence in the resistors capability, saving costs and reducing engineering time.

In recent years, particularly in marine applications, Certificates of Conformity or Authenticity are often required by the end-user. Danotherm is accustomed to such demands and is able to provide documents on the origin of materials and the conformity of processes e.g. for steel and welding processes. FAT (Factory Acceptance Test) with the customer and or a Accrediting Company like Lloyds, DSV or RINA is very well possible. The production facility is optimised for small and medium scale production runs.

At Danotherm, Resistor division, we are dedicated to design and produce advanced and optimised resistors and welcome new design challenges that drive our customers' success.





DANOTHERM™

WHDN fully welded steel tank resistors are offered with tank diameters ranging from 100mm to 300mm.

The resistor unit consists of steel resistor elements with a diameter of 16mm which are welded in a flange that is fitted to the tank. Different alloys can be used for both resistor elements and tank and connection box. The resistor unit is fitted on a flange and is closed with a gasket. With this construction it is possible to open the resistor and clean the inside of the tank.

The electrical configuration can be single, star/delta or multiple segments. Inside the connection box are the main terminals and the secondary circuits such as box heater, thermal protection circuits and air bubble detection circuit.

The resistor can be equipped with a drain, closing or pressure valves. Standard mounting position is horizontal but vertical types are available (with limited heights).



WHDN

General specifications WHDN

Nominal power		40 kW - 1450 kW
Working voltage		1000 VAC / 1400 VDC
Dielectric strength @ 50Hz, 1 min.		3,500 V
Insulation resistance @ 5000 VDC	dried condition	>> 10 MΩ
Overload @ 1s pulse / hour		8 x Pn (depends on R value)
Overload @ 5s pulse / hour		4 x Pn (depends on R value)
Resistance tolerance	standard	± 10%
	optional	± 5% / ± 3%
Temperature coefficient	20 °C - 400 °C	85 ppm/K
Time constant for heating up		30s
Protection degree		IP65 / IP66
Cooling fluid		fresh water / water-glycol
Maximum temperature liquid inlet	without de-rating	* 60 °C
ΔT inlet/outlet (recommended)		10 K - 20 K
Pressure drop @ Pn and Δ20K		0.3 bar
Materials	optional	AISI 316
- tank	standard	AISI 304
- connection box	standard	AISI 304
- resistor elements	standard	incoloy800
	optional	AISI 321, incoloy825
- cable gland	optional	nickel plated brass / AISI 304
	standard	undrilled plate
Mounting, maintenance and storage instructions		available document
Water temp. protection		Thermostat
- range (advised 10K + T water out)		0 °C - 150 °C
- contact		Change-over contact
- max. current		16 A
Air bubble protection		Thermostat
- range (advised 180°C)		50 °C - 300 °C
- contact		Change-over contact
- max. current		16 A
Moisture protection	standard	20 W - 30 W heating cable 230 V
- voltage	optional	115 V
Factory acceptance tests	standard	
		- Aspect / dimensional Inspection
		- Resistance value
		- Insulation resistance
		- Dielectric strength
		- Pressure test
	optional	Certified Body witness test
PT100 + transducer	optional	
Pressure sensor 4-20mA	optional	

Dimensions WHDN 100

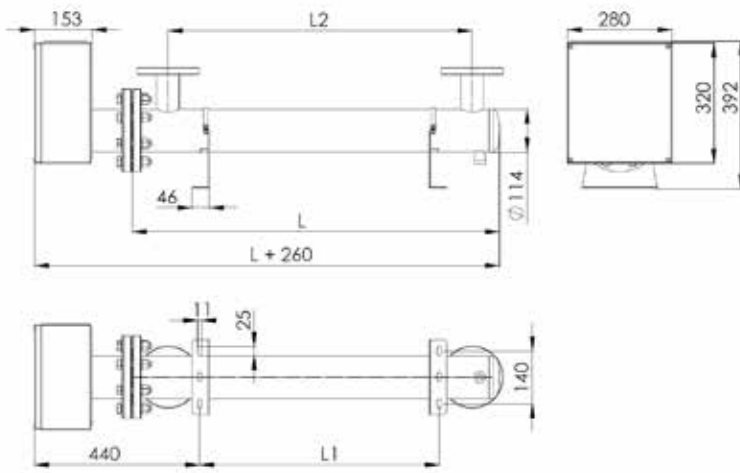

Type	Power [kW]	Length [mm]	Weight* [kg]
WHDN 100-1000	40	1000	40
WHDN 100-1200	50	1200	45
WHDN 100-1400	60	1400	50
WHDN 100-1600	70	1600	55
WHDN 100-1800	80	1800	60
WHDN 100-2050	90	2050	66
WHDN 100-2450	110	2450	76
WHDN 100-2850	130	2850	86
WHDN 100-3100	140	3100	92

Dimensions WHDN 150

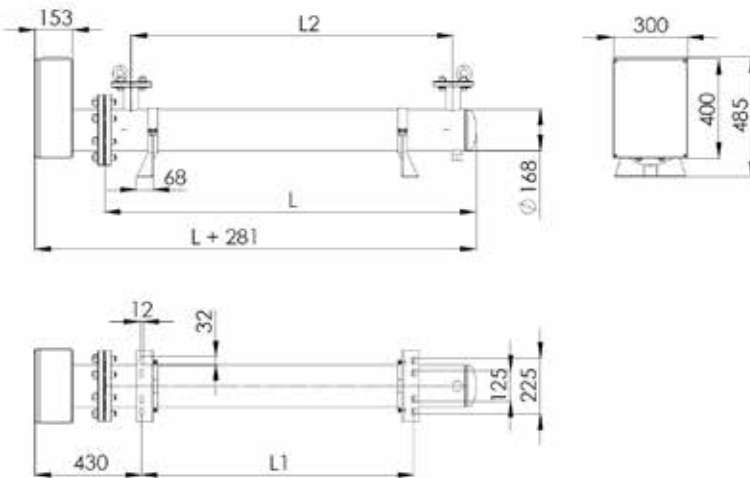

Type	Power [kW]	Length [mm]	Weight* [kg]
WHDN 150-1200	100	1200	90
WHDN 150-1300	110	1300	92
WHDN 150-1500	130	1500	100
WHDN 150-1700	150	1700	105
WHDN 150-2000	175	2000	115
WHDN 150-2250	200	2250	125
WHDN 150-2500	225	2500	130
WHDN 150-2750	250	2750	140
WHDN 150-3100	284	3100	150

Dimensions WHDN 200

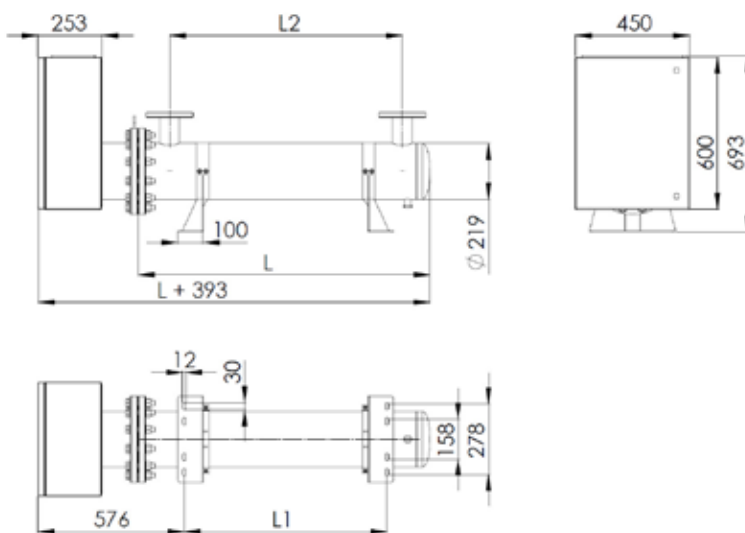

Type	Power [kW]	Length [mm]	Weight* [kg]
WHDN 200-1100	150	1100	130
WHDN 200-1250	175	1250	135
WHDN 200-1400	200	1400	140
WHDN 200-1700	250	1700	150
WHDN 200-2025	300	2025	170
WHDN 200-2350	350	2350	180
WHDN 200-2650	400	2650	190
WHDN 200-2950	450	2950	205
WHDN 200-3100	475	3100	210

* approximate weight

Dimensions WHDN 250

Type	Power [kW]	Length [mm]	Weight [kg]
WHDN 250-1375	350	1375	225
WHDN 250-1550	400	1550	240
WHDN 250-1750	460	1750	255
WHDN 250-1900	500	1900	270
WHDN 250-2050	550	2050	280
WHDN 250-2250	600	2250	295
WHDN 250-2400	650	2400	305
WHDN 250-2600	700	2600	325
WHDN 250-2750	750	2750	335
WHDN 250-2925	800	2925	350
WHDN 250-3100	850	3100	360

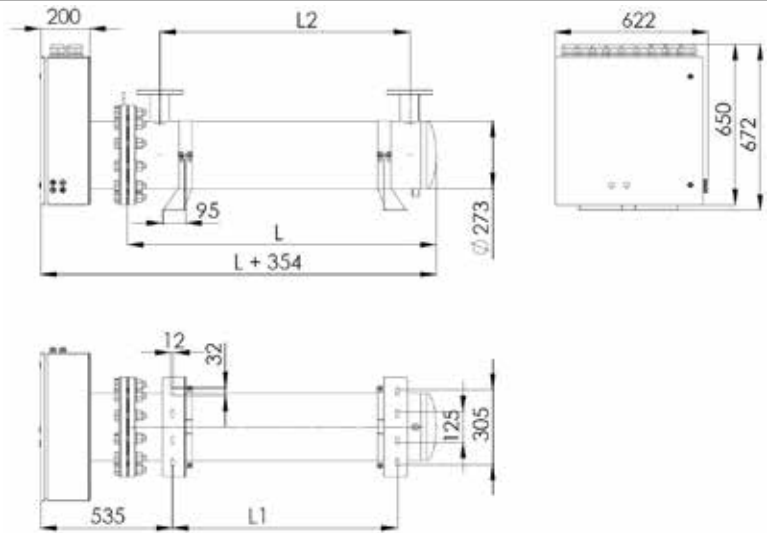

Dimensions WHDN 300

Type	Power [kW]	Length [mm]	Weight [kg]
WHDN 300-1600	700	1600	450
WHDN 300-1825	800	1825	475
WHDN 300-2025	900	2025	495
WHDN 300-2250	1000	2250	520
WHDN 300-2450	1100	2450	540
WHDN 300-2650	1200	2650	575
WHDN 300-2850	1300	2850	610
WHDN 300-3100	1450	3100	650

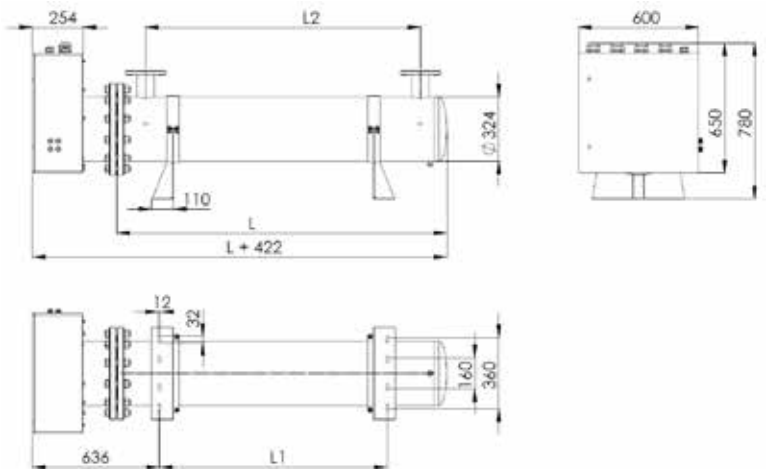

Overview WHDN

Type	WHDN 100	WHDN 150	WHDN 200	WHDN 250	WHDN 300
Diameter tank	114.3	168.3	219.1	273	323.9
Main flange	DN100	DN150	DN200	DN250	DN300
in-/out flange					
- Nipples 2"G Threaded male	√	√			
- DN50	√	√	√		
- DN65	√	√	√	√	√
- DN80			√	√	√
- DN100					√
Max working pressure	10	10		8	8
Test pressure	16	16		12	12

Coolant

Water flow in L / minute	ΔT 10K	ΔT 15K	ΔT 20K
power			
50	85	55	42
75	125	85	65
100	170	110	85
200	340	225	170
300	500	340	250
400	670	450	340
500	840	560	420
700	1200	790	590
1000	1700	1100	840

Calculation of water coolant flow in liters per second is based on the formula:

$$Q = m \cdot C_{th} \cdot \Delta T$$

In which Q = energy (in Joules)

C_{th} = thermal capacity of coolant. For water use 4.18 J/g.K

m = mass of coolant to pass the resistor per second

ΔT = temperature increase of the coolant (Outlet temp.–Inlet temp.)

When using glycol mixture obtain the correct thermal capacity of the coolant to re-calculate. Values may vary from 2.8 to 3.4 J/g.K

WHDN type resistors are available in horizontal and vertical style. Hereunder you find as an example the mechanical drawing of type WHDN 200 V. Vertical types are limited in height.

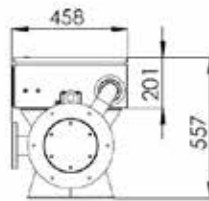
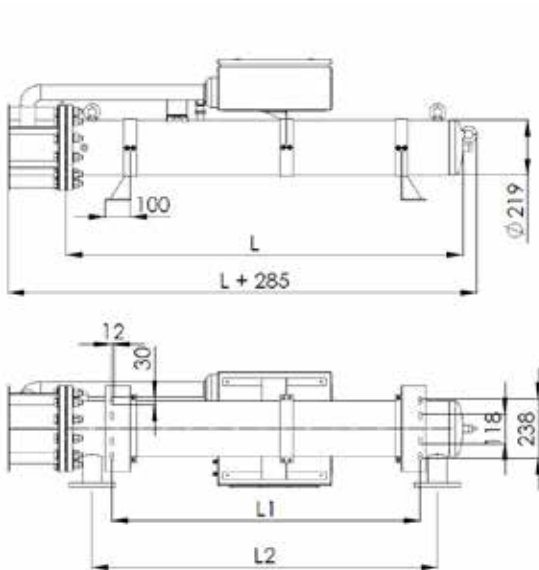

WHDN 200 V





DANOTHERM™

WHHB fully welded steel resistor has a high working voltage. The active resistor wire is in direct contact with the coolant and must be cooled with de-ionised water with or without glycol. The water in-and outlet is on top of the resistor.

WHBS 16 fully welded steel resistor can have three or six steel tubes of 16mm diameter, welded in a steel tank. The water in-and outlet can be on top of the resistor or at the rear side. The connection can be 'open style' with threaded rods M6, IP00, or the resistor can be fitted with a connection box IP65/IP66.

WHBS 32.4 fully welded steel resistor has mica insulated resistor elements. It has a high working voltage. The water in-and outlet is at the rear side of the resistor.

All fully welded steel resistor have a test pressure according EN 13455 of 12 psi.

WHB 16.3 has an aluminium housing with gasgets. It has three steel tube resistor elements and can be with or without connection box. The water in-and outlet is at the rear of the resistor.

HVB resistors are aluminum housed resistor for energy dump applications. They have a high working voltage. The resistor element is insulated and has a sand filling (SiO) or magnesium oxide (MgO) to handle high energy pulses.



WHHB / WHBS / WHB

General specifications WHHB

Nominal power	standard	25 kW
Working voltage		6.6 kVDC
Dielectric strength @ 50Hz, 1 min.		20 kV
Resistance tolerance	standard	± 10%
	optional	± 5%
Max. current	50mm ²	160 A
	250mm ²	500 A
Protection degree		IP65
Cooling fluid		Deionised water or deionised water-glycol
- Conductivity of fluid		≤ 2µS/cm
- Maximum fluid inlet temperature		* 60 °C
- ΔT inlet/outlet (recommended)		≤ 15 K
- Pressure drop @ 30L/min.		≤ 0.5 bar
Materials		
- housing (not in contact with fluid)	standard	anodized aluminium
- resistor elements		nickel chrome alloy
Operating pressure		6 bar @ 55 °C
Test pressure		10 bar @ 20 °C

Dimensions WHHB with 50mm² connectors

Type	Power [kW]	Length [mm]	Weight [kg]
WHHB 550	6 - 25	550	≈ 15

Ohmic range 1R - 200R

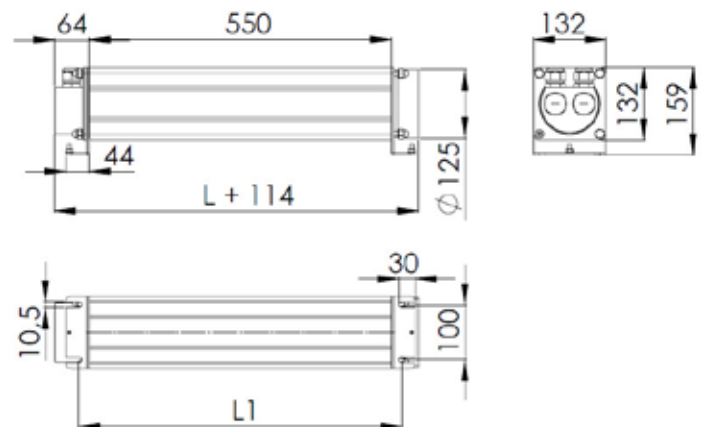

Dimensions WHHB with 250mm² connectors

Type	Power [kW]	Length [mm]	Weight [kg]
WHHB 550	6 - 25	550	≈ 20

Ohmic range 50mR - 800mR

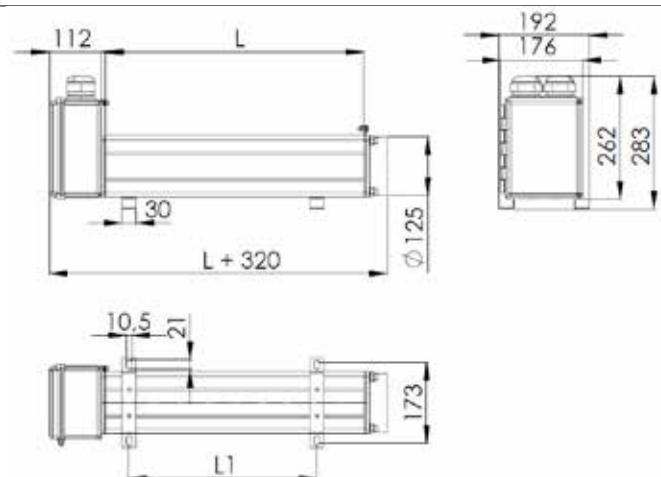

* depends on cooling fluid pressure and additives

General specifications WHBS 16

Nominal power		6 kW - 100 kW
Working voltage		1000 VAC / 1400 VDC
Dielectric strength @ 50Hz, 1 min.		3,500 V
Insulation resistance @ 5000 VDC	dried condition	>> 10 MΩ
Overload @ 1s pulse / hour		8 x Pn (depends on R value)
Overload @ 5s pulse / hour		4 x Pn (depends on R value)
Resistance tolerance	standard	± 10%
	optional	± 5% / ± 3%
Temperature coefficient	20 °C - 400 °C	85 ppm/K
Time constant for heating up		30s
Protection degree		IP65 / IP66
Maximum liquid inlet temperature		* 60 °C
ΔT inlet/outlet (recommended)		10 K - 20 K
Operating pressure		6 bar @ 55 °C
Test pressure		12 bar @ 20 °C
acc. EN 13445		16 bar @ 20 °C
Pressure drop @ Pn and 20K		0.5 bar
Cooling fluid		fresh water / water-glycol
Maximum temperature liquid inlet	without de-rating	* 60 °C
ΔT inlet/outlet (recommended)		10 K - 20 K
Materials	optional	AISI 316
- tank	standard	AISI 304
- connection box	standard	AISI 304
- resistor elements	standard	AISI 304
	optional	AISI 321, incoloy 800, incoloy825
Drain / air bubble release	optional	
Temperature protection	standard	Thermostat
- normally closed		16 A @ 230 VAC
Temperature sensor PT100	optional	
Air bubble protection	optional	Thermostat
Moisture protection	optional	15 W - 30 W heating cable
- voltage	optional	230 V or 115 V



Dimensions WHBS 16.3 with M6 terminals or cable lugs

Type	Power [kW]	Length [mm]	Weight [kg]
WHBS 16.3.600	6	300	5
WHBS 16.3.800	8	400	6
WHBS 16.3.1000	11	500	7
WHBS 16.3.1200	13	600	8
WHBS 16.3.1400	15	700	10
WHBS 16.3.1600	18	800	11
WHBS 16.3.1800	20	900	12
WHBS 16.3.2000	23	1000	13

- Protection degree IP00
- Very low Ohm values with M8/lugs and reduced power
- Other values with M6 rods

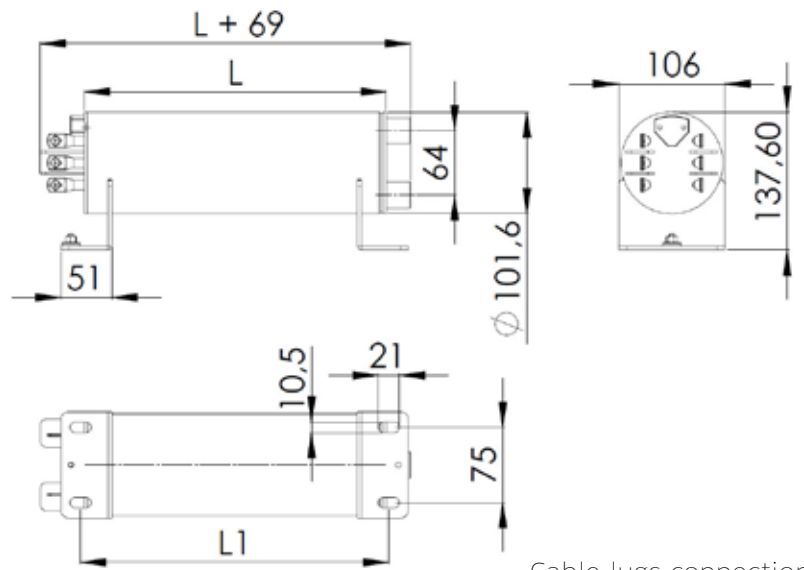

Cable lugs connection

Dimensions WHBS 16.3 with connection box

Type	Power [kW]	Length [mm]	Weight [kg]
WHBS 16.3.600	6	300	7
WHBS 16.3.800	8	400	8
WHBS 16.3.1000	11	500	9
WHBS 16.3.1200	13	600	10
WHBS 16.3.1400	15	700	12
WHBS 16.3.1600	18	800	13
WHBS 16.3.1800	20	900	14
WHBS 16.3.2000	23	1000	15

Protection degree IP65/IP66

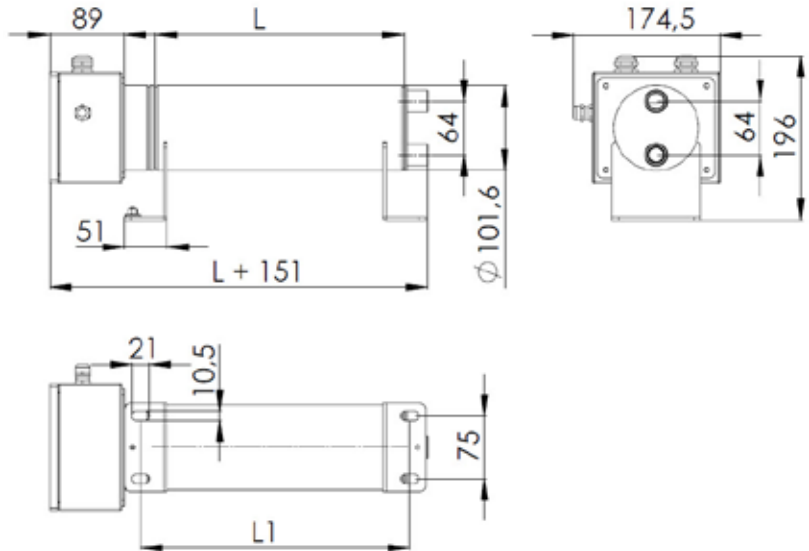

Dimensions WHBS 16.6 connection box

Type	Power [kW]	Length [mm]	Weight [kg]
WHBS 16.6.800	16	400	16
WHBS 16.6.1000	20	500	18
WHBS 16.6.1400	30	700	22
WHBS 16.6.1800	40	900	26
WHBS 16.6.2200	50	1100	30
WHBS 16.6.2600	60	1300	34
WHBS 16.6.3000	70	1500	38
WHBS 16.6.3400	80	1700	42
WHBS 16.6.3800	90	1900	46
WHBS 16.6.4200	100	2100	50

Protection degree IP65/IP66

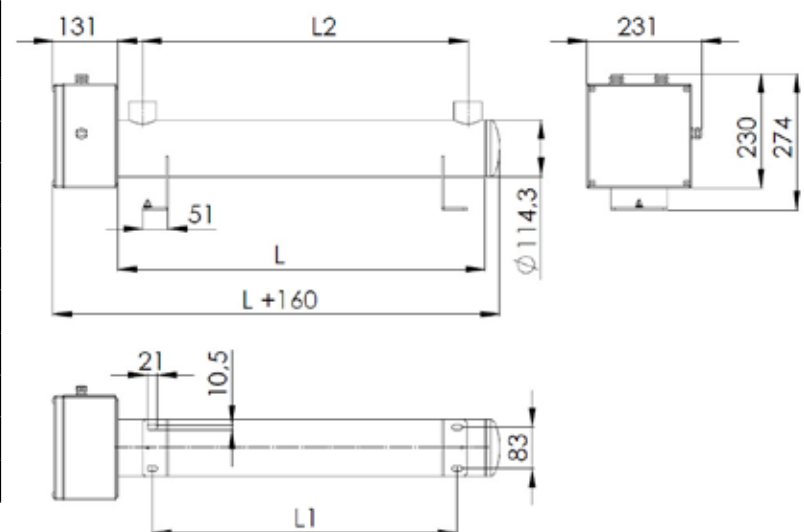

Dimensions WHBS 32.4.500

Type	Length	Weight
WHBS 32.4.485	485 mm	15 kg

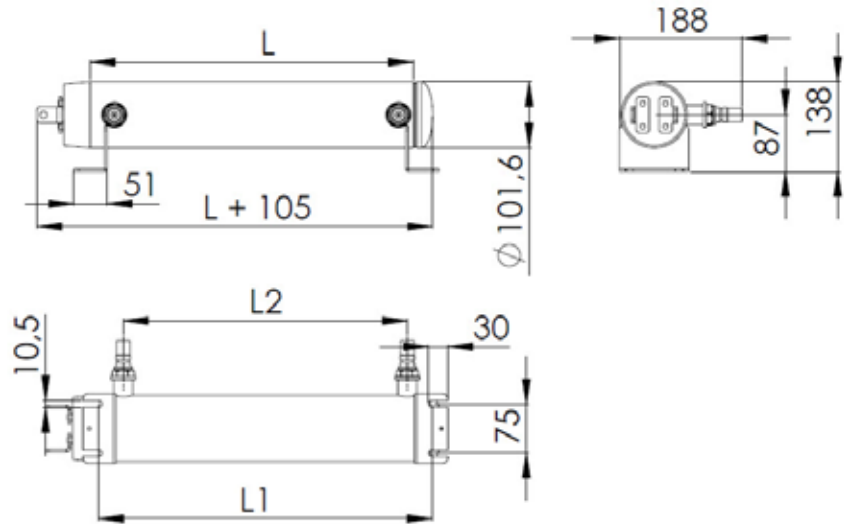

General specifications WHBS 32.4.485

Nominal power		3 kW - 6 kW
Working voltage		1000 VAC - 3000 VAC
Dielectric strength @ 50Hz, 1 min.		10k V
Insulation resistance @ 5000 VDC	dried condition	>> 20 MΩ
Overload @ 1s pulse / hour		20 x Pn (depends on R value)
Overload @ 5s pulse / hour		10 x Pn (depends on R value)
Resistance tolerance	standard	± 10%
	optional	± 5% / ± 3%
Time constant for heating up		60s
Protection degree		IP00
Maximum liquid inlet temperature		* 60 °C
ΔT inlet/outlet (recommended)		10 K - 20 K
Operating pressure		6 bar @ 55 °C
Test pressure		10 bar @ 20 °C
acc. EN 13445		16 bar @ 20 °C
Pressure drop @ 9L/min		0.5 bar
Cooling fluid		fresh water / water-glycol
Material (tank fully welded)	standard	AISI304



WHHB 550



WHBS 32



WHB 16.3



WHBS 16.3

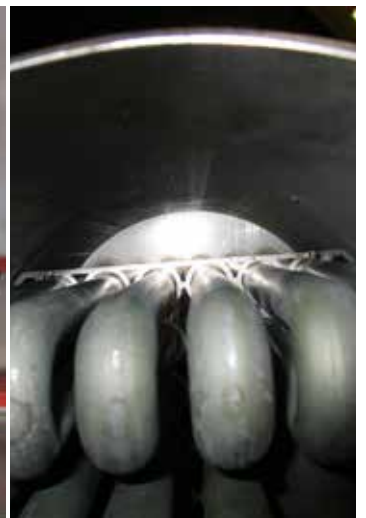

General specifications WHB

Nominal power		6 kW - 23 kW
Working voltage		1000 VAC / 1400 VDC
Dielectric strength @ 50Hz, 1 min.		3,500 V
Insulation resistance @ 5000 VDC	dried condition	>> 10 MΩ
Overload @ 1s pulse / hour		8 x Pn (depends on R value)
Overload @ 5s pulse / hour		4 x Pn (depends on R value)
Resistance tolerance	standard	± 10%
	optional	± 5% / ± 3%
Temperature coefficient	20 °C - 400 °C	85 ppm/K
Time constant for heating up		30s
Maximum liquid inlet temperature		* 60 °C
ΔT inlet/outlet (recommended)		10-20 K
Operating pressure		6 bar @ 55 °C
Test pressure		10 bar @ 20 °C
acc. EN 13445		11 bar @ 20 °C
Pressure drop @ 9L/min		0.5 bar
Cooling connection		¼" / ½"
Material housing		anodized aluminium
- connection box	optional	aluminium

Dimensions WHB 16.3 cable box

Type	Power [kW]	Length [mm]	Weight [kg]
WHB 16.3.600	6	300	7
WHB 16.3.800	8	400	8
WHB 16.3.1000	11	500	9
WHB 16.3.1200	13	600	10
WHB 16.3.1400	15	700	12
WHB 16.3.1600	18	800	13
WHB 16.3.1800	20	900	14
WHB 16.3.2000	23	1000	15

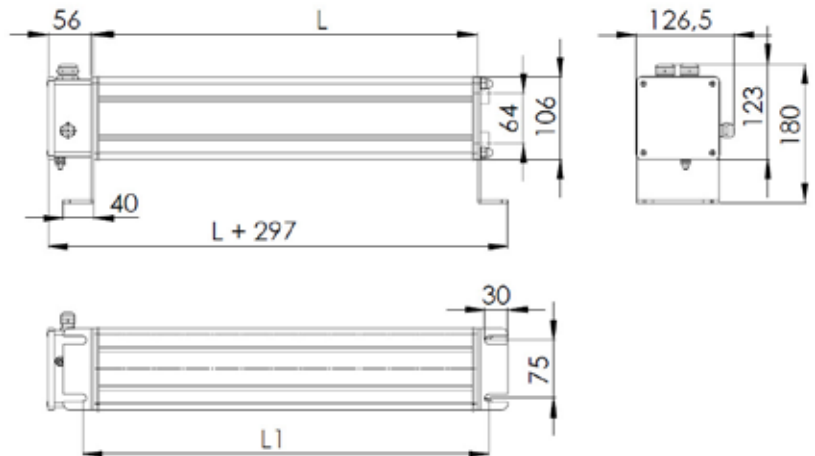

Protection degree IP65

connection treaded rods M6

Dimensions WHB 16.3 connection with M6 treaded rods

Type	Power [kW]	Length [mm]	Weight [kg]
WHB 16.3.600	6	300	6
WHB 16.3.800	8	400	7
WHB 16.3.1000	11	500	8
WHB 16.3.1200	13	600	9
WHB 16.3.1400	15	700	11
WHB 16.3.1600	18	800	12
WHB 16.3.1800	20	900	13
WHB 16.3.2000	23	1000	14

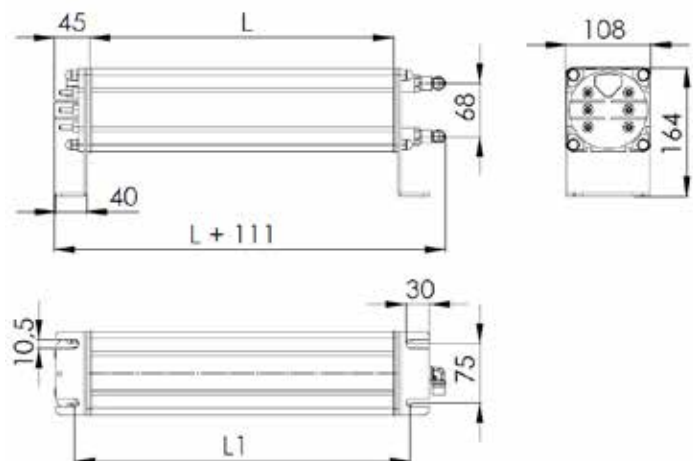

- Protection degree IP00

- Very low Ohm values with M8/lugs and reduced power

- Other values with M6 rods

General specifications HVB

Energy rating 5s*	HVB 70.400.1	150 kJ - 285 kJ
	HVB 70.400.2	300 kJ - 570 kJ
Resistance tolerance		± 10%
temperature coefficient		100 ppm/K
Working voltage		4,500 V
Dielectric strength @ 50 Hz, 1 min.		10 kV
Insulation resistance @ 5 kVDC	dried condition	≥20MΩ
Connection	standard	Radox cable 1000 mm
Protection degree		IP65
Cooling		natural air cooled
Material housing		anodised aluminum



HVB 70.400.1



HVB 70.400.2

Dimensions HVB 70.400.1

Type	Length	Weight
HVB 70.400.1	400 mm	4.5 kg

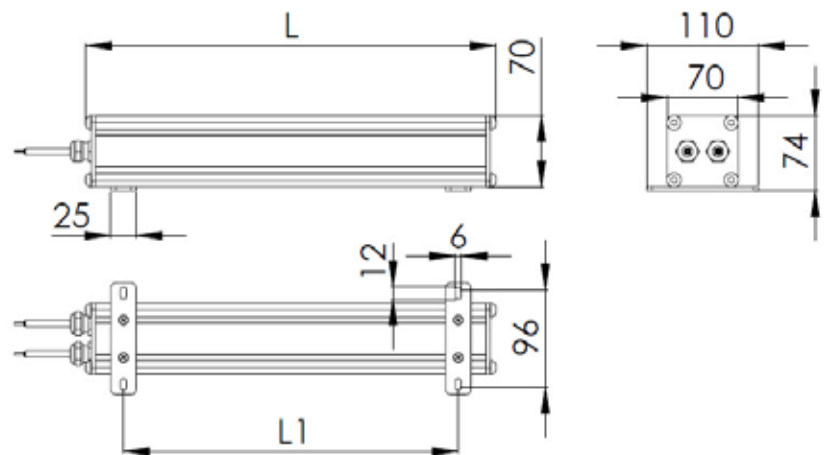

Dimensions HVB 70.400.2

Type	Length	Weight
HVB 70.400.2	400 mm	9 kg

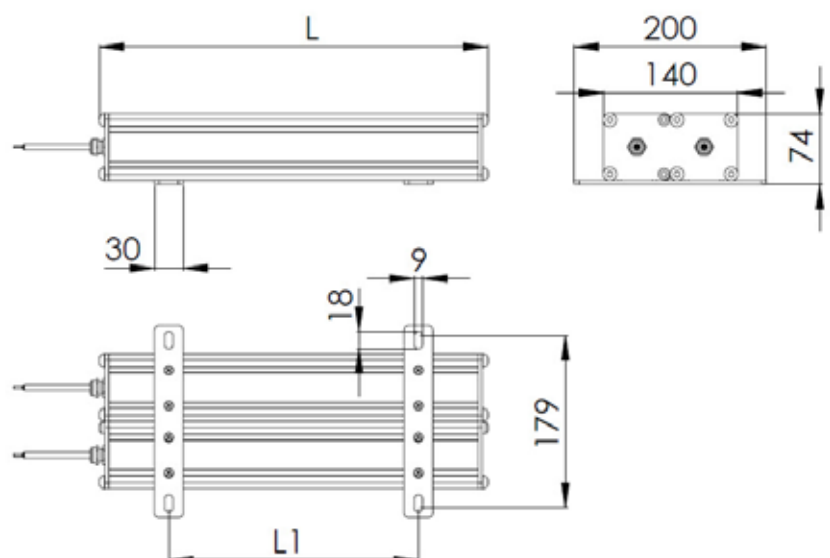

* depends on Ohmic value



DANOTHERM™

TRV steel tubes forced air cooled resistors have two or four powerful ventilators as active cooling. The tubes can be made from different alloys to meet the environmental conditions. The frame work and connection box are offered in AISI304 and AISI316. Inside the connection box are the main terminals, the cabinet heater and all secondary circuits. Protection degree is IP65 or IP66.

GxxRT are natural air cooled steel tubes resistors. They can have three, nine, ten or twelve tubes welded into a frame. The connection box contains the main terminals and any auxiliary circuits. The ingress protection degree is IP65. A protection grid is optional.



TRV / GxxRT

General specifications TRV

Power ratings		50 kW - 275 kW
Temperature coefficient	20 °C - 400 °C	85 ppm/K
Working voltage		1000 VAC / 1400 VDC
Dielectric strength @ 50Hz		3,500 V
Insulation resistance @ 5000VDC	dried condition	>> 10 MΩ
Overload @ 5s pulse / hour		7 x Pn (depends on R value)
Overload @ 10s pulse / hour		5 x Pn (depends on R value)
Resistance tolerance	standard	± 10%
	optional	± 5% / ± 3%
Electrical circuit configuration	standard	single resistor unit
	optional	star/delta/split configuration
Environmental conditions	temperature range	-20 °C - 40 °C
	altitude	1000 m
Time constant for heating up		60s
Protection degree		IP65 / IP66
Fans	standard voltage	415 V, 3-phase, 50 Hz
	optional voltage	430 V, 3-phase, 60 Hz
	power	1.5 kW per motor
	protection degree	IP66
	air flow	5000 m³/h per motor
	motor	steel, marine environment painted
ΔT between inlet and outlet air		≈ 50 K
Materials	optional	AISI 316, AISI 321, incoloy825
- support/panels	standard	AISI 304
- connection box	standard	AISI 304
- resistor elements	standard	incoloy800
- cable gland	optional	nickel plated brass / AISI 304
	standard	undrilled plate
Moisture protection	standard	100 W - 120 W heating cable 230 V
- voltage	optional	115 V
Factory acceptance test	standard	- Aspect and dimensional Inspection
		- Resistance value
		- Insulation resistance
		- Dielectric strength
		optional

Please, read carefully the instructions on page 20 about contacts and sensors.

Contacts and sensors

3.1 Schematic diagram

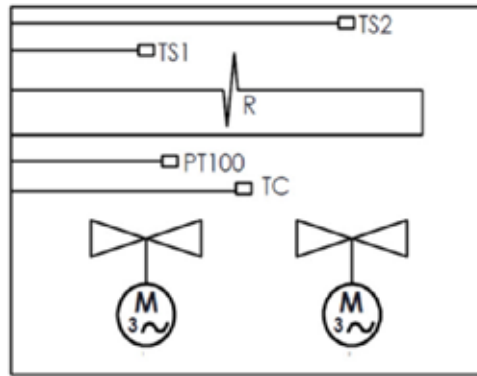

3.2 Thermal protections TS1 and TS2

Each resistor section has two protection thermo contacts. The sensors are placed opposite the corresponding Fan. Setting range 50 - 300°C. Form-C contact, rated 20A-AC1. Advised setting 200°C. These contacts serve to indicate malfunction from each Fan.

All contacts are wired in series as N.C. contact. The customer MUST connect this series connection to a control unit that MUST switch off the load in case this contact opens due to over temperature.

Connection diagram:

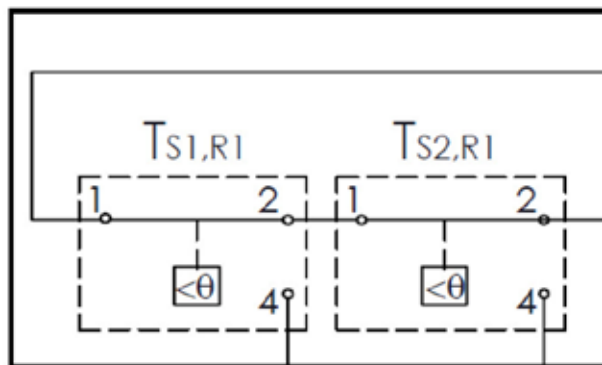

3.3 Temperature contact TC

Each resistor section has one thermo contact to start the cooling. It is positioned in the middle of each section. Setting range 0 - 100°C. Form-C contact, rated 20A-AC1. Advised setting 70°C. These contacts serve to start Fan-1&2 (at the same time).

Connection diagram:

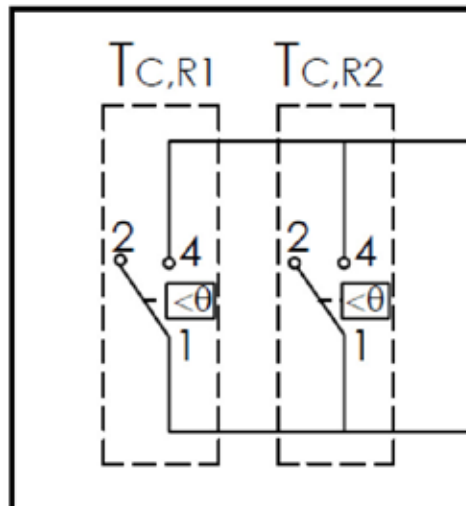

3.4 Temperature sensor Pt100 (option)

This resistor unit is supplied with (multiple) Pt100 sensor(s), 4-wire type with/without signal convertor. These sensors serve to monitor the temperature from each section.

See wiring diagram for connections.

3.5 Moisture protection

The electrical connection box has a moisture protection inside the silicone potting. Electrical data: supply voltage 230V AC/DC - consumption 120W. The heater is self-regulating and keeps the temperature 10-20°C above ambient, with a limit of 60°C. The heater must always be 'ON', certainly, when the resistor is NOT operational.

Dimensions TRV

Type	Power	Airflow	Weight			steel AISI 304		steel AISI 316		
				A	B	C	D	E	D	E
		m ³ /hour	Kg	mm	mm	mm	mm	mm	D	E
TRV 18.1950 _ 50kW	50		200							
TRV 28.1950 _ 75kW	75	10,000	220	1345	640	720	805	665	865	725
TRV 36.1950 _ 100kW	100		240							
TRV 45.1950 _ 125kW	125		300							
TRV 55.1950 _ 150kW	150	16,000	330	1345	640	720	1105	965	1165	1025
TRV 64.1950 _ 175kW	175		360							
TRV 72.1950 _ 200kW	200		450							
TRV 82.1950 _ 225kW	225	28,000	470	1395	1040	1120	955	815	1115	875
TRV 90.1950 _ 250kW	250		500							
TRV 100.1950 _ 275kW	275		550							

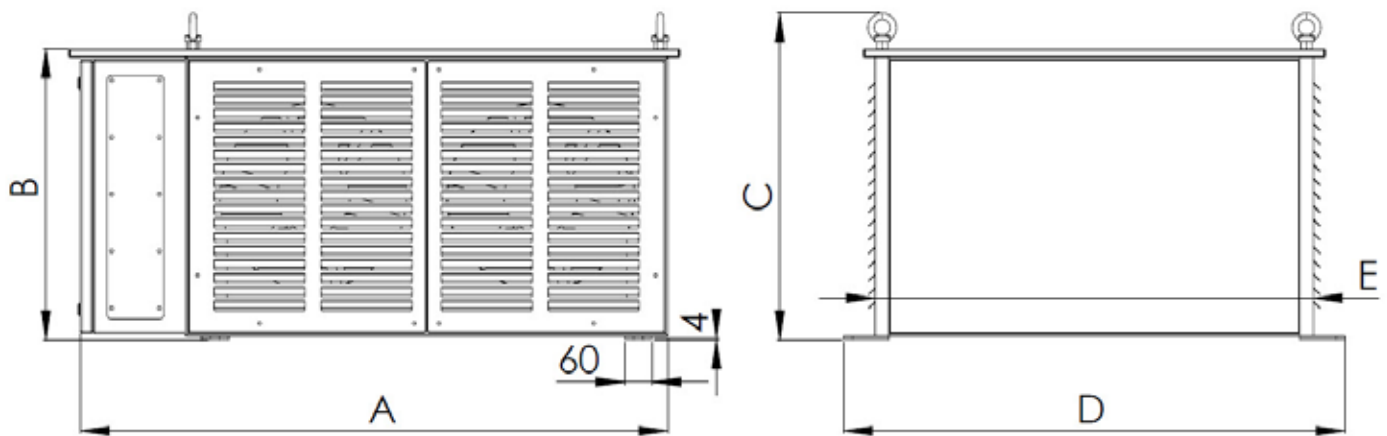

General specifications GxxRT

Nominal power		3 kW - 32 kW
Working voltage		1000 VAC / 1400 VDC
Dielectric strength @ 50Hz, 1 min.		3,500 V
Insulation resistance @ 5000 VDC	dried conditions	>> 10 MΩ
Overload @ 5 pulse / hour		10 x Pn (depends on R value)
Overload @ 10s pulse / hour		7 x Pn (depends on R value)
Resistance tolerance	standard	± 5%
	optional	± 5% / ± 3%
Temperature coefficient		100 ppm/K
Time constant for heating up		
Protection degree		IP65
Cooling		natural air cooled
Configuration	standard	single phase
	optional	delta/star 3 phase
	optional	multiple segments
Thermal protection	standard	thermal switch
- normally closed contact		2 A @ 250 VAC, 50 Hz, cos 0.95
Moisture protection	standard	7.5 W - 30 W heating cable 230 V
- voltage	optional	115 V
Mechanical protection against direct contact with hot elements	optional	protection grid
Materials		
- R-elements	standard	AISI304
	optional	AISI321, Incoloy 825
- Terminal box	standard	AISI304
- Supporting structure	standard	AISI304
	optional	AISI316
Factory acceptance test	standard	
		- Aspect and dimensional Inspection
		- Resistance value
		- Insulation resistance
		- Dielectric strength

Dimensions G03RT

type	Power [kW]	Length [mm]
G03RT16-900	3.00	450
G03RT16-1200	4.00	600
G03RT16-1500	5.00	750
G03RT16-1700	6.00	850

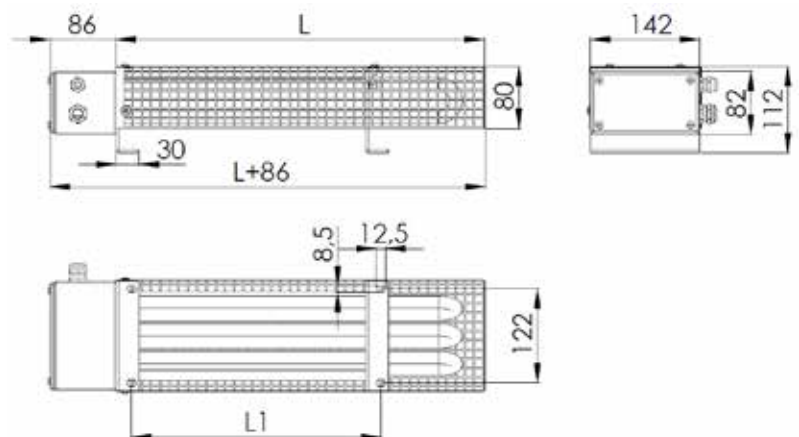

G03RT including optional protection grid

Dimensions G09RT

type	Power [kW]	Length [mm]
G09RT16.1000	7.00	500
G09RT16.1100	7.75	550
G09RT16.1300	9.50	650
G09RT16.1500	11.00	750
G09RT16.2200	16.50	1100

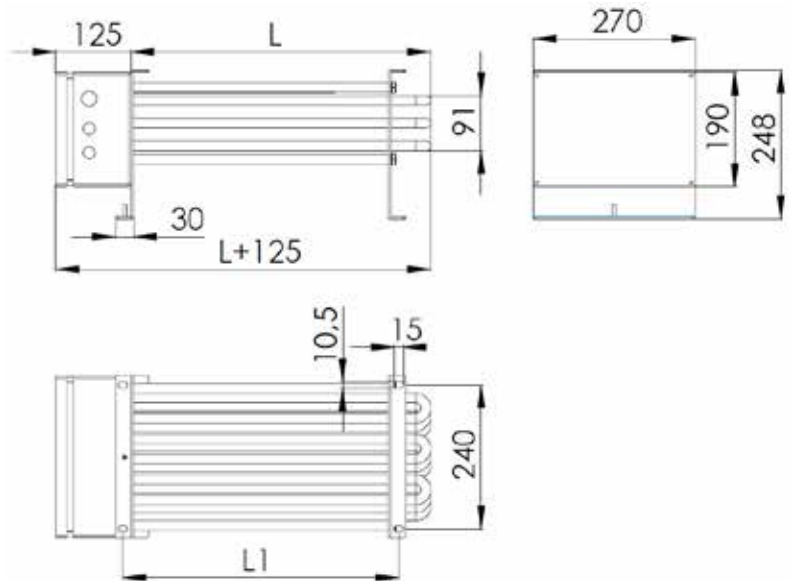

Dimensions G10RT

type	Power [kW]	Length [mm]
G10RT16.1000	7.50	500
G10RT16.1200	9.50	600
G10RT16.1400	11.25	700
G10RT16.1600	13.00	800
G10RT16.1800	14.75	900
G10RT16.2000	16.50	1000
G10RT16.2200	18.25	1100
G10RT16.2400	20.00	1200
G10RT16.2600	21.75	1300
G10RT16.2800	23.50	1400
G10RT16.3000	25.50	1500
G10RT16.3200	27.00	1600

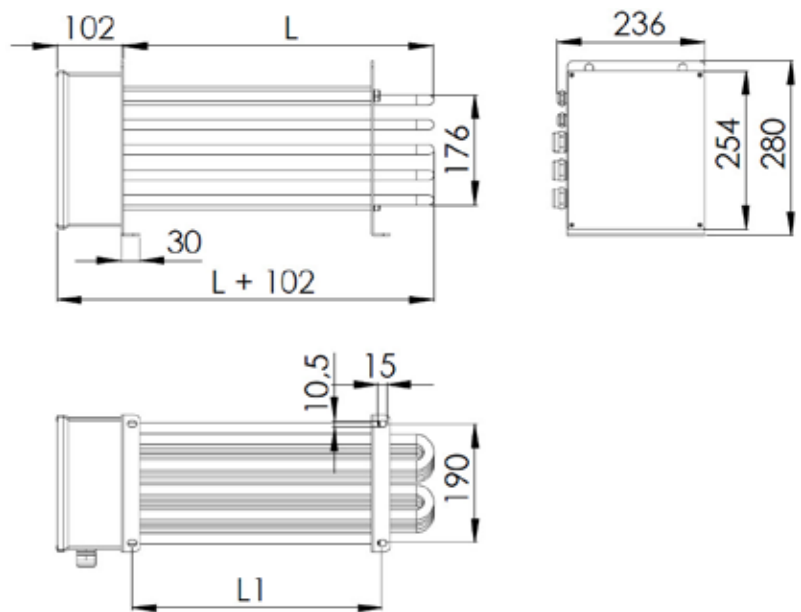

Dimensions G12RT

type	Power [kW]	Length [mm]
G12RT16.1000	9.00	500
G12RT16.1200	11.40	600
G12RT16.1400	13.50	700
G12RT16.1600	15.60	800
G12RT16.1800	17.70	900
G12RT16.2000	19.80	1000
G12RT16.2200	21.90	1100
G12RT16.2400	24.00	1200
G12RT16.2600	26.10	1300
G12RT16.2800	28.20	1400
G12RT16.3000	30.60	1500
G12RT16.3200	32.40	1600

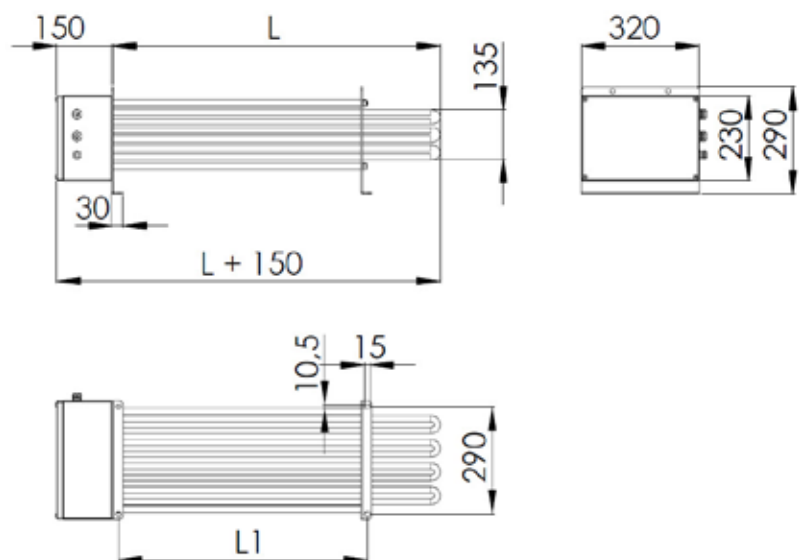

Overview of the ALPHA resistor family (IP00-IP65)



Power: 60-410W	Power: 85W-1.7kW	Power: 410W-12kW	Power: 445W-15kW	Power: 860W-25kW
	9-150kJ @5s	25-550kJ @5s	80kJ-2.5MJ @5s	6.4kJ-1.1MJ @5s
- Applications	- Applications	- Applications	- Applications	- Applications
Charge / Discharge	High Pulse load	High Pulse load	High Pulse load	Short recovery time
Brake	Brake	Brake	Brake	Brake
Filter	Filter	Filter	Medium voltage	Filter
Charge / Discharge	Charge / High Pulse	Charge / High Pulse	Charge / High Pulse	High Pulse

Other resistor types from Danotherm (IP00-IP65)



Multi purpose	Outdoor & Marine	Filter	Medium & HV	Filter & load
Power: 100W-5kW	Power: 1-500kW	Power: 4-200kW	Power: 500W->	Power: 5kW-1MW
Ceramic wirewound	Steel tube	Wirewound	Steel grid	Steel tube

Official Danotherm dealer



Danotherm Electric A/S
 Naesbyvej 20
 DK-2610 Roedovre
 Denmark
 CVR 1012 6061

REBA EN 18.5055.1
 26APR2018